

AM · FM · TELEVISION

# BROADCAST

## NEWS





## **DISTANCE**-*dissolved!*

THESE USAF GLOBAL BOMBERS are maintaining direct radio contact with their base back home—TWO CONTINENTS AWAY!

How is it accomplished? RCA's revolutionary new ARC-21 communications equipment . . . the most advanced of its kind in the world . . . enables them to make full use of favorable radio conditions as they change throughout the world.

From a choice of several thousand channels, the operator pre-selects the most effective group of frequencies for reliable communications between planes, or between a plane and any point on earth. *Automatically*, the transmitter and receiver tune to the frequency in use. *Automatically* the antenna circuits match up to the antenna for each change in frequency.

Helping to solve radio communications problems is just one of the many ways RCA is assisting our Armed Forces to ensure U. S. supremacy in electronics. Be sure to get acquainted with the RCA engineers and Field Technicians in your branch of service.



**RADIO CORPORATION of AMERICA**

ENGINEERING PRODUCTS DEPARTMENT

CAMDEN, N.J.

# Broadcast News

AM • FM • TELEVISION

Published by the

RADIO CORPORATION OF AMERICA

ENGINEERING PRODUCTS DEPARTMENT . . . CAMDEN, NEW JERSEY

NUMBER 72

JANUARY-FEBRUARY, 1953

### Subscription Rates

In continental U. S. A. - \$4.00 for 12 issues  
In other countries - - - \$5.00 for 12 issues

JOHN P. TAYLOR, Editor

W. O. HADLOCK, Managing Editor

M. L. GASKILL, E. C. MASON, Associate Editors

## Contents

MORE ON UHF COVERAGE . . . . .	by JOHN P. TAYLOR	8
TELEVISION — WHAT AND HOW TO BUILD . . . . .	by RENE BRUGNONI AND BEN ADLER	12
WCAU's NEW RADIO AND TELEVISION CENTER . . . . .	by JOHN G. LEITCH	26
PRACTICAL APPLICATIONS OF MICROPHONES FOR TELEVISION . . . . .	by H. M. GURIN	52
TYPE BHF-50A, 50-KW HIGH FREQUENCY TRANSMITTER . . . . .	by C. J. STARNER	58
HAM FORUM . . . . .	by M. L. GASKILL	66

Copyright 1953  
Radio Corporation of America  
RCA Victor Division  
Camden, N. J.

TMKS ®

PRINTED  
IN  
U.S.A.

**OUR COVER**, as we hardly need tell you, goes with the article which starts on Pg. 12. The color sketch was made by Rene Brugnani, one of the authors. Which reminds us to remind you that we would like to have a few comments on cover illustrations. In particular, which kind do you like best? Those reproduced from color photographs, usually with stark realism? Or those which, like the cover on this issue, are reproduced from drawings—drawings that usually have a little more imagination in them?

**OLD TIMERS TOOK OVER** this issue, and it wasn't premeditated either. Every article is by an author who has contributed articles to previous issues. The editor, whose little squib appears on Pg. 8, holds the record. He had an article in BROADCAST NEWS Volume I (October, 1931). What was the subject? You guessed it . . . an article entitled "What Is Your Coverage?" Subject seems to have fascinated him, for in the twenty-two years since, he has perpetrated several more on the same subject. And, as a quick perusal of the story starting on Pg. 8 will prove, he still doesn't know all the answers.

Next "old timer" author is Ben Adler, co-author with Rene Brugnani, of the article starting on Pg. 12. Ben's first article appeared in BROADCAST NEWS Volume No. 4 (July 1932). It described WFLA's revolutionary new antenna, the first use of a directional antenna for broadcasting in this country. Ben's estimate that it was a newsworthy installation turned out to be true. Ben, too, has written many other articles for BROADCAST NEWS over the years.

Still another old time author is Jack Leitch, whose detailed description of the new WCAU is the feature article of this issue (Pg. 26). Jack's first article in BROADCAST NEWS appeared in Volume No. 7 (April 1933). That first article, entitled "WCAU—A Modern Monument To The Art Of Broadcasting", described that year's new WCAU studios, as notable then as the studios described on Pg. 26 are today.

Hank Gurin (Pg. 52) and Charlie Starnier (Pg. 58) don't go back quite so far. However, both have contributed to BROADCAST NEWS before. And both, need we say, on almost the same subjects they write of in this issue. You might say that this is an issue turned out by the "old pros".

**WE'RE SORT OF PROUD** of our WCAU business. It's not just the fact that practically all of the equipment in the new WCAU building described on Pg. 26 is RCA. Rather it is the even more impressive fact that for over twenty years nearly all of the equipment selected by WCAU for its operations has been RCA. In 1932 WCAU built a brand new studio building at 1622 Chestnut Street. It was the largest and finest independent station layout built up to that time. The equipment was all RCA. The same year WCAU installed its first 50 kw transmitter—an RCA 50-B. After the war, when WCAU moved its transmitter plant to a new site, it installed all new equipment, including a new RCA 50 kw transmitter of improved all air-cooled design—the 50-E. In 1948 when WCAU went into television it purchased all RCA equipment; cameras, studio equipment, transmitter and antenna (BROADCAST NEWS, No. 54). And now, of course, it has again bought RCA for its new radio-TV plant. This we feel is a record to be proud of.

It's not a record that was easily made. We did not get this business on a silver platter—nor through "connections". Almost the contrary! Moreover, anyone who knows Jack Leitch, and almost everyone in the industry does, knows that he is a perfectionist on technical operation. Anyone who knows him well knows how hard he is to satisfy. In fact, there have been times when to do so we have had to change the design of the equipment to incorporate changes suggested by the WCAU engineering staff. This does not make us feel badly. Quite the opposite. Because, from the WCAU engineers—and from the engineers of many other stations—we are continually learning how to make our equipment better suit their needs. From this interchange we both benefit.

# RCA

# UHF

AGAIN, RCA sets a record in UHF technical leadership—by delivering to KPTV the entire UHF transmitter plant that put the FIRST commercial UHF signals on the air.

Out of the experimental field into the practical, RCA transmitter-antenna combinations like those shown here make UHF planning a practical reality. They enable you to obtain the most coverage at minimum investment.

◀ RCA UHF PYLON ANTENNA. The high-gain TV antenna that includes a vertical beam-fill arrangement—enabling you to cover specific areas more effectively. Horizontal radiation pattern of the Pylon is virtually circular.

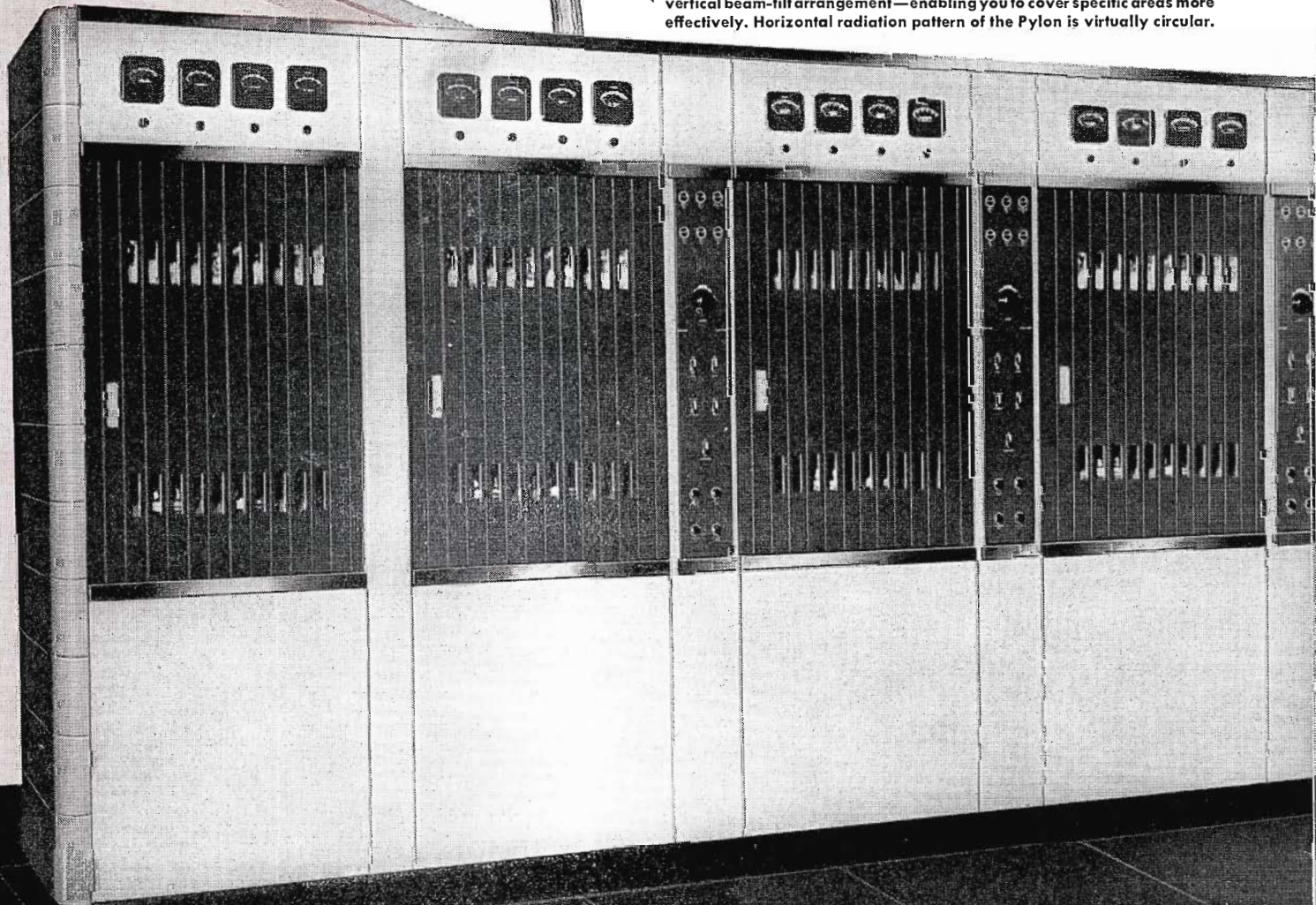

10-KW TYPE TTU-10A (FOR ERP\* TO 270 KW). This UHF transmitter, and a UHF Pylon Antenna, will produce from 240 to 270 kw ERP on channels 14 to 83. The combination is capable of serving almost any metropolitan area with strong signals. Type TTU-10A is designed for straight-line or block "U" arrangements.

\* Effective Radiated Power

# proved in Portland!

For example, in low-power operation, RCA's low-cost 1-kw UHF transmitter and a high-gain Pylon Antenna combination is the most economical choice. Or, if you require higher power, RCA's "10-kw" UHF and a high-gain Pylon combination approaches the ultimate in useful coverage.

In addition to transmitter-antenna combinations, RCA also has the UHF accessories you need to go "on air"; transmitter monitoring equipment, trans-

mission line fittings, towers, consoles, UHF loads and wattmeters, Filterplexers, etc. Everything is "systems matched" to work together for maximum performance. All equipment is available from ONE responsible transmitter manufacturer—RCA.

Make sure YOU get your UHF equipment when you need it. Your RCA Broadcast Sales Representative is ready to take your order—and show you what you need to go UHF at lowest cost.

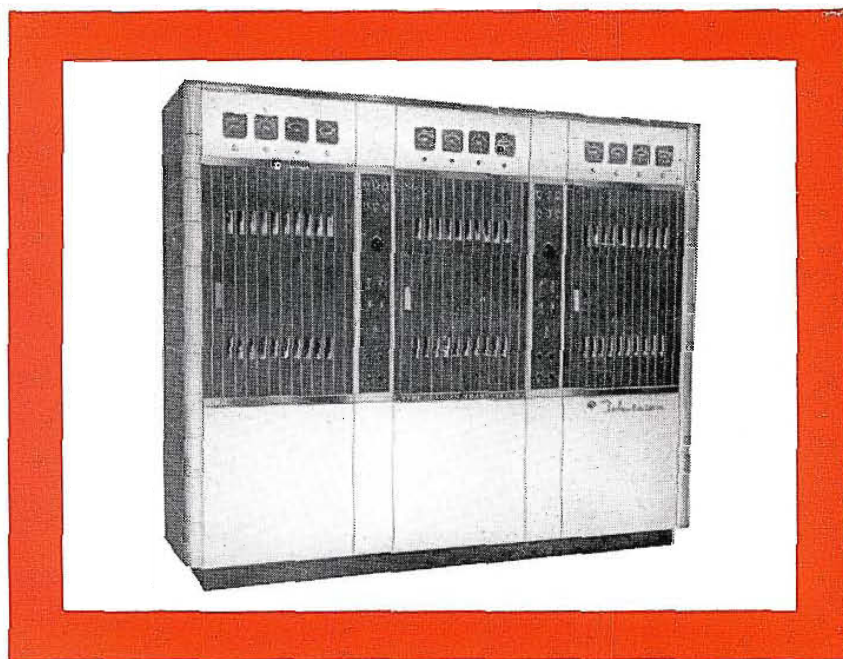
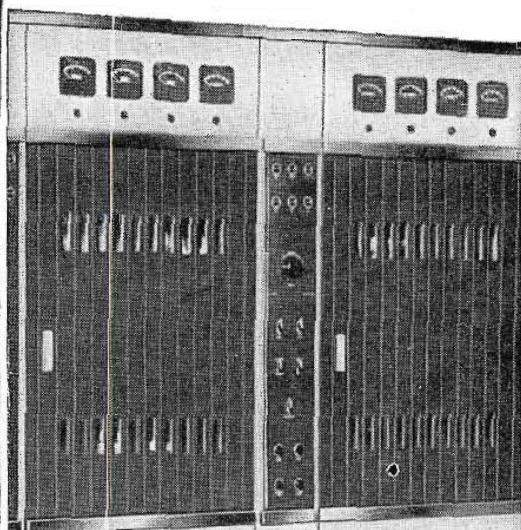

1-KW TYPE TTU-1B (FOR ERP\* TO 27 KW). This transmitter and a UHF Pylon Antenna, can develop from 24 to 27 kw ERP on any channel, 14 to 83. TTU-1B is self-contained and all air-cooled. It is well suited as a driver for a high-power amplifier.



**RADIO CORPORATION of AMERICA**  
ENGINEERING PRODUCTS DEPARTMENT

CAMDEN, N. J.

# Complete "Package"

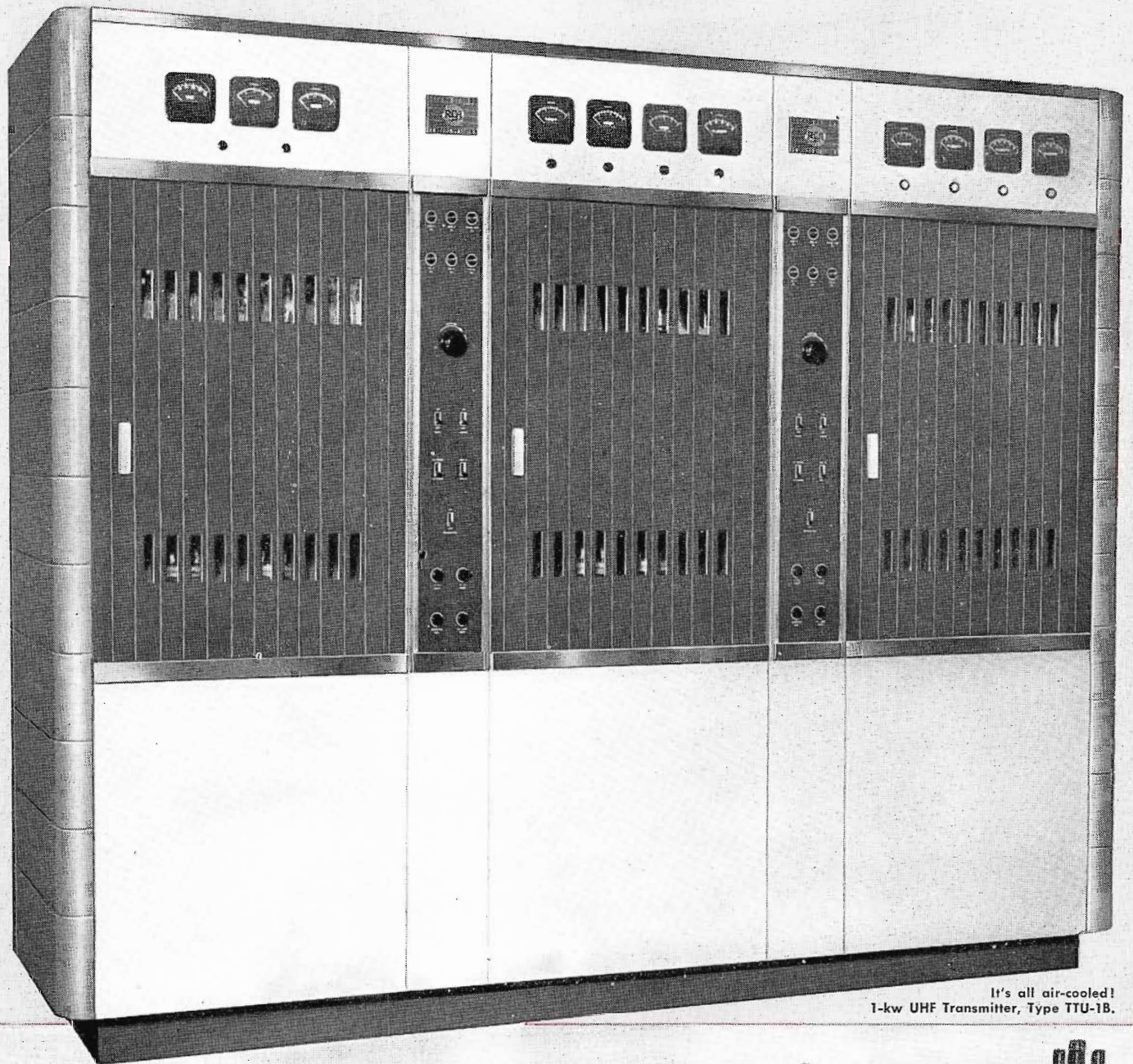

It's all air-cooled!  
1-kw UHF Transmitter, Type TTU-1B.

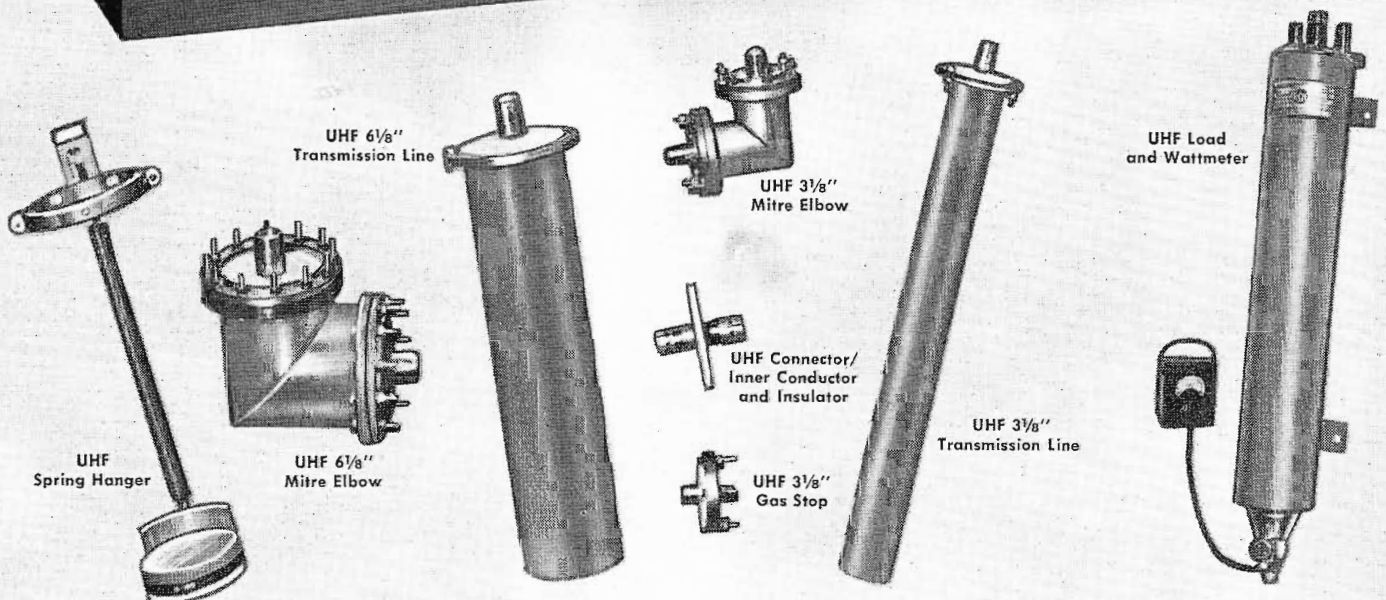

*for*

# UHF

## Transmitter Plants

WITH THE UHF EQUIPMENT and accessories illustrated here, you can build a 1-kw UHF plant capable of delivering up to 20 kw, ERP. RCA has the transmitter. RCA has the antenna. RCA has the indispensable accessories needed to complete the installation—transmission line, mitred elbows, line transformers, spring hangers, dummy loads, wattmeters, frequency and modulation monitors, filterplexers, etc. In short, everything—from ONE responsible manufacturer!

What about a power increase later? The 1-kw transmitter can be used to drive an RCA 10-kw high-power amplifier.

Like this 1-kw package, RCA has UHF combinations to meet power requirements—up to 1000 kw! Your RCA Broadcast Sales Representative can tell you what you'll need for the power you use—show you a practical plan for a minimum outlay. Call him today.



**RADIO CORPORATION of AMERICA**  
ENGINEERING PRODUCTS DEPARTMENT  
CAMDEN, N.J.

EVERY TECHNICAL ACCESSORY FOR A UHF TRANSMITTER PLANT

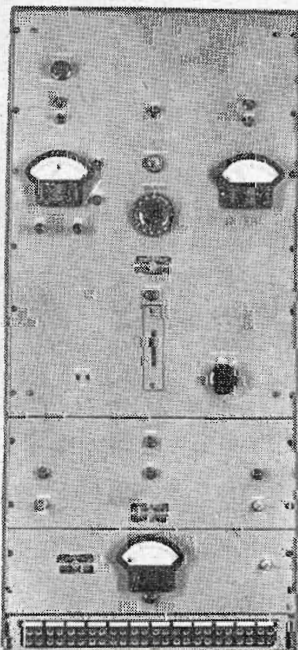

UHF Frequency and Modulation Monitors

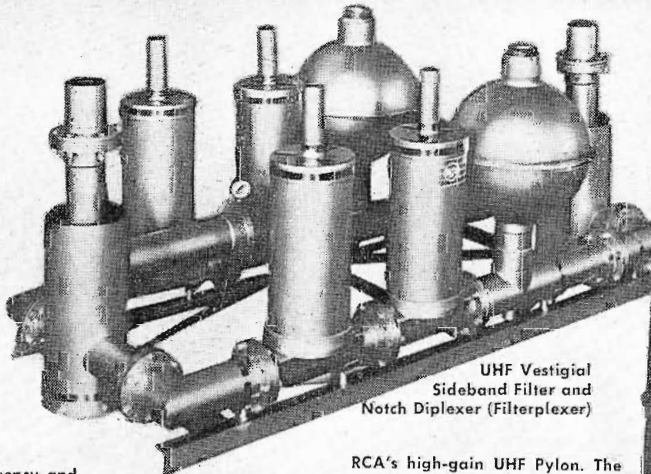

UHF Vestigial Sideband Filter and Notch Diplexer (Filterplexer)

RCA's high-gain UHF Pylon. The most economical way known to produce high ERP.

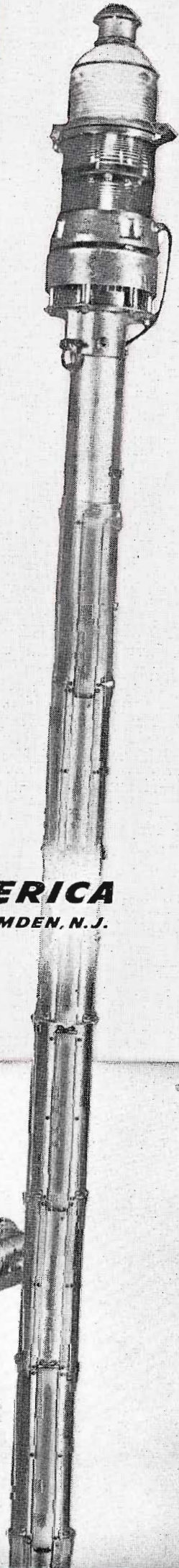

# RCA's TV "Basic"

TRANSMITTER  
AND  
CONTROL ROOM

1-KW UHF  
TRANSMITTER

ENGINEERING  
WORKSHOP

VIDEO/AUDIO  
CONTROL CONSOLE

ANNOUNCE  
STUDIO

PROJECTION  
FACILITIES

Typical BASIC BUY station for UHF—complete with RCA 1-kw transmitter and antenna. Delivers up to 20 kw, ERP. Provides four program services. No local talent or local pick-ups needed. Size of transmitter, unit arrangement, and future plans determine the floor area (layout here is only 30' x 20'). For higher power, add an RCA 10-kw amplifier to the "1-kw". Add studio facilities any time.



# Buy" does the most

**-with the least TV equipment  
-VHF or UHF!**

## 4 PROGRAM SERVICES

— no local studios needed!

- Network programs
- Local films (16mm)
- "Stills" from local slide projector
- Test pattern from monoscope (including individualized station pattern in custom-built tube)

THIS PICTURE ILLUSTRATES what we think is the minimum equipment a TV station should have to start with—and earn an income. The arrangement can handle any TV show received

from the network and provides station identification and locally inserted commercials as required. In addition, it offers an independent source of revenue—by including film and slide facilities for handling local film shows and spots, or network shows on kine recordings.

The BASIC BUY includes: A transmitter and an antenna (necessary for any TV station); monitoring equipment (required by FCC); film and slide equipment (for local programs—and extra income); monoscope camera for reproducing a test pattern of known quality (important for good station operation and as an aid to receiver adjustment); and a control console that saves operator time and effort (it enables one technical

man to run the station during nearly all "on-air" periods).

RCA's BASIC BUY can be used in combination with any RCA TV transmitter and antenna, of any power—VHF or UHF. Matched design and appearance make it easy to add facilities any time (you need never discard one unit of a basic package). And note this: *RCA BASIC UNITS ARE IDENTICAL TO THE RCA UNITS USED IN THE BIGGEST TV STATIONS!*

RCA's BASIC BUY is already being adopted by many TV station planners. Let your RCA Sales Representative work out a flexible package like this for you—show you how to do the most with the least equipment!

### This is what the BASIC BUY includes!

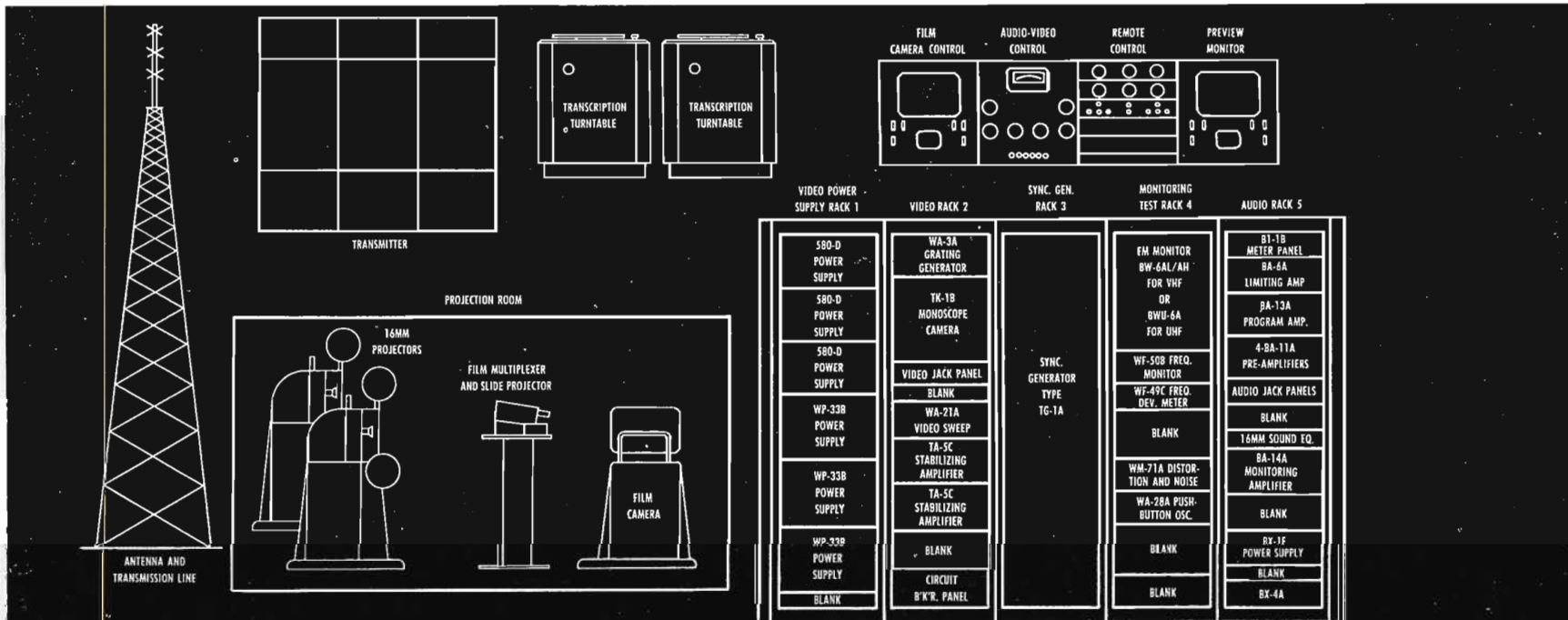

**RADIO CORPORATION of AMERICA**  
ENGINEERING PRODUCTS DEPARTMENT  
CAMDEN, N.J.

# MORE REPORTS ON UHF COVERAGE

## PRELIMINARY MEASUREMENTS AT YORK, SOUTH BEND AND ATLANTIC CITY CONFIRM EARLIER FINDINGS AT PORTLAND

by **JOHN P. TAYLOR**  
Editor

In the last issue we presented a personal report on the coverage which KPTV, the first commercial UHF TV station, was getting in the Portland area.<sup>1</sup> Although the results reported were fairly conclusive as to service in Portland, it remained to be seen whether similar results would be achieved in other localities. Somewhat rashly we

<sup>1</sup> "UHF In Portland—How Is It Doing?" by John P. Taylor, BROADCAST NEWS, No. 71, September-October, 1952.

promised to print similar information on the coverage of other stations as it became available.

With 10 RCA-built UHF transmitters now on the air (as of February 19th), and new ones going on at a rate of several a month, some additional information on UHF coverage is beginning to come in. So far, it is not extensive; however, some interesting ideas can be gleaned from it. The following is our own personal interpretation of this information (which does not necessarily represent the opinions of our engineers).

### Quick Summary

What does this new information show? To summarize it briefly, it seems to indicate that the picture of UHF coverage drawn from the survey at Portland is essentially correct, and that the results obtained at Portland will be duplicated by other stations (making due allowance, of course, for differences in height, terrain, frequency and distribution of population).

Moreover, this confirmation of the Portland results applies not only to the main conclusions, which we felt were proven by the measured data, but also to several other ideas which were expressed as things we felt to be true, but which were not provable by the measured data. It even applies to the "reservations" we expressed on the last page of the Portland story, wherein we pointed out rather sharply that the results obtained elsewhere would be different if the antenna height, terrain, etc., were different. And especially that we did not know how much different. Some readers apparently read only the first two pages (the most enthusiastic part) of the Portland story. Conversation with them indicates they did not read, or did not take seriously enough, the "qualifications" in the last pages of the story. We recommend that they go back and read that part—and that they read the paragraph entitled "Warning" at the end of this article.

### Information Now Available

New information on UHF coverage falls in two categories. First, there are numerous reports from individuals connected with stations, service shops and manufacturers. Most of these reports are spotty, a lot of them are colored by the observer's wishful thinking, and all of them depend on the observer's own idea of a "good picture". Thus, by themselves, these reports aren't worth much. All summed up they do have one value. This is that almost always these reports are more optimistic than our own measured results. The importance of this is that it indicates that the standards we have set are conservative, which is as it should be.

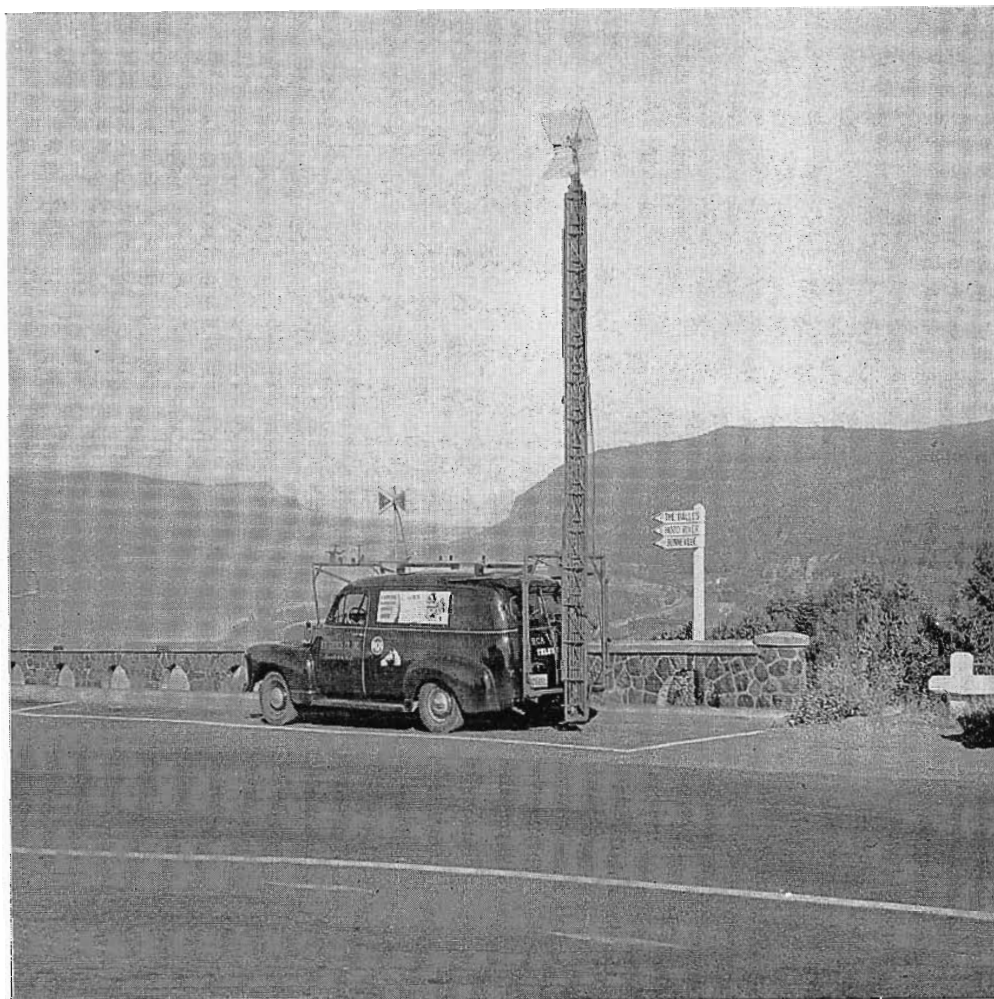

FIG. 1. Field trucks such as the one shown here were used by engineers of the RCA Service Company in making the measurements at York, South Bend and Atlantic City, which are reported in the accompanying article.

FIG. 2 (right, above). Plot of field intensities measured at KPTV, Portland, Oregon. Solid curve is from FCC's F(50,50) Table for indicated power and antenna height. Broken curve is the "free space" field strength for this power.

FIG. 3 (right, below). Plot of field intensities measured at WSBT-TV, South Bend, Indiana.

The second, and more important, new addition to our information on UHF coverage is in the form of actual field intensity measurements of three stations' signals which have been made by engineers of the RCA Service Company. In December, RCA shipped the first three "production model" UHF transmitters to stations WFPG-TV, Atlantic City; WSBT-TV, South Bend; and WSBA-TV, York. Within a few days thereafter all three were on the air, making them the second, third and fourth UHF stations to go into actual operation. In order to have essential information for its installation and service operation the RCA Service Company immediately sent engineers to all three cities to make quick preliminary field surveys. These engineers, working under the direction of Merrill Gander, Chief Engineer of the RCA Service Company, were all men with some experience in this field. The equipment they used, and the method of measurement, was sufficiently similar to that used at Portland so that direct comparisons are justified. Thus we now have an approximate indication of the average signal levels of four stations—where before we had such information on only one.

**Method of Measurement**

For their measurements the RCA Service Company engineers used field trucks fitted with calibrated field strength measuring equipment, monitoring receivers and antenna towers which could be raised to 70 feet. In each instance measurements were made at intervals along several radials from the station. The measured points were selected to be free of local shadowing (such as houses, large tree clumps). Using a corner reflector antenna the field intensity was measured at a height of 30 feet at each point (and at other heights for some points). This method of spot measurement is more likely to introduce errors due to purely local factors than that used at Portland (where in each instance a short "run" was made). However, the fact that "clear" locations were chosen for measurement probably means that in most cases the measured signal was typical of the area.

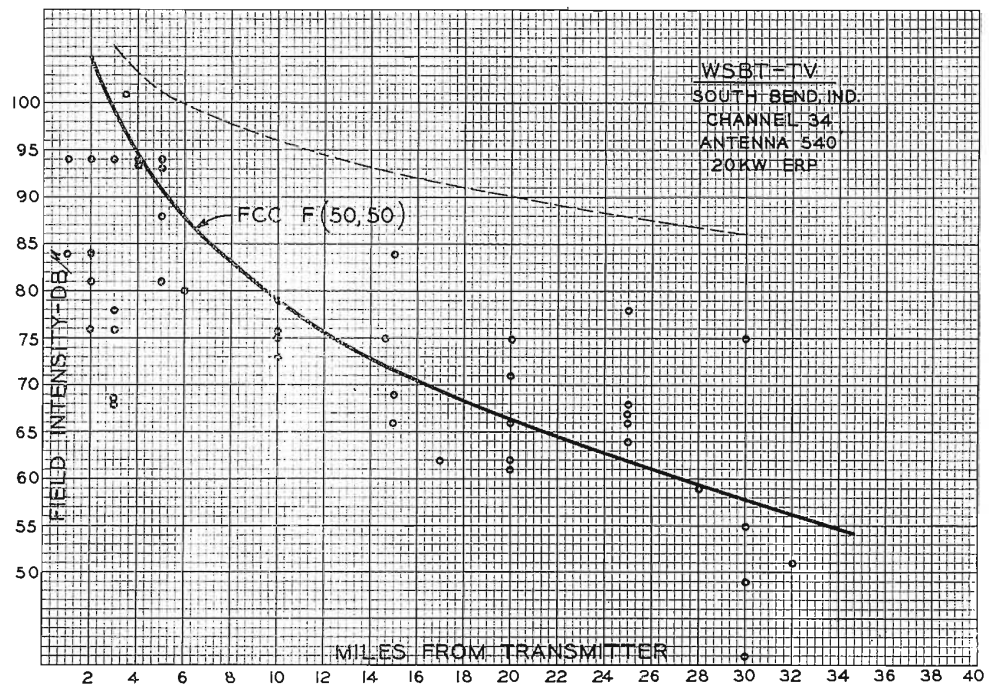
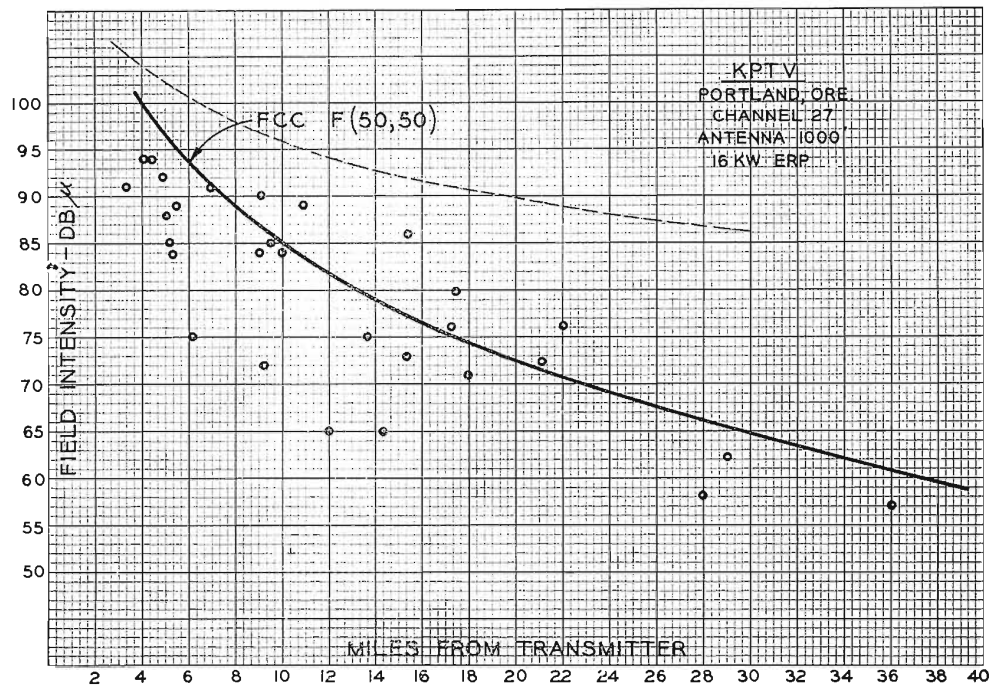

**Plotting the Data**

In order to give a quick visualization of the measured results, the field strength measured at each of the three stations has been plotted in Figs. 3, 4, and 5. A similar curve for KPTV Portland is shown in Fig. 2. In each case all points on all of the radials have been plotted on one graph. This makes the engineers shudder, but we feel that it gives a quick visualization of "overall" performance of the station. On each graph the small circles indicate measured values. The solid curve is the FCC's F(50,50) curve for the antenna height and reflective radiated power of the station. The broken curve near the top is the field

intensity which would be measured in "free space" for the equivalent power and distance.

**Discussion of Plotted Curves**

It will be remembered that at Portland we concluded that the FCC F(50,50) curve corresponded fairly well with the median of our measurements (excepting a few very deeply shadowed points). Study of Figs. 3, 4, and 5 shows that, within an approximation, this is also true for the other three stations. At Atlantic City and South Bend the country is relatively flat and the correspondence is fairly good. At York there was considerable difference in the eleva-

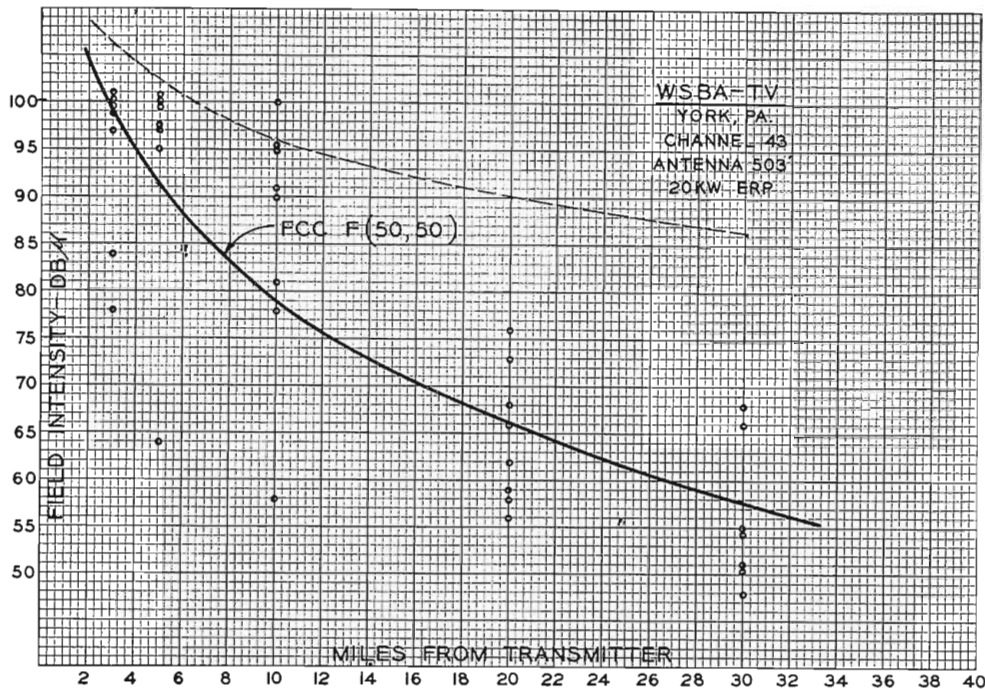

FIG. 4 (left). Plot of field intensities measured at WSBA-TV, York, Pa.

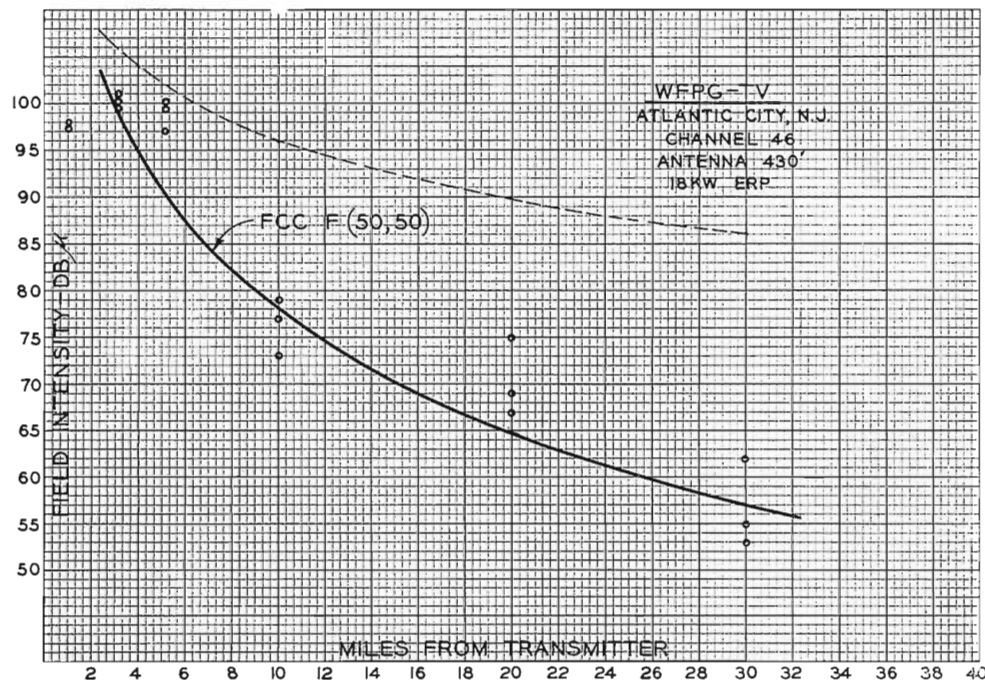

FIG. 5 (left). Plot of field intensities measured at WFG-TV, Atlantic City, New Jersey.

tions along the several radials. Some of them were through relatively flat country. Several were in rolling country, and two were in very hilly areas. As expected the signals measured along the latter are very low. If these are excluded we find the solid curve is about the median value for all points.

In addition to making the the actual measurements the RCA Service Company engineers also made notations of the picture quality at each point. Averaging these out they check very well with our observations at Portland, namely that a field intensity of 64 dbu (1.6 mv/m) is the very minimum for "good picture" quality (as-

suming a good antenna at a height of 30 feet).

Some observations of the effect of different types of shadowing were also made. However, these were made at random locations and do not add much to our knowledge of reception in shadowed areas. Insofar as they can be interpreted they bear out in all instances our previous observations.

#### What Does It Add Up To?

The measurements on these three new stations would seem to indicate that what we found at Portland will be true elsewhere. Essentially this is that for flat or gently rolling terrain the FCC F(50,50)

curves give a good indication of median signal levels to be expected at various distances. This does not mean that every location at a given distance will receive the signal level indicated by the curve. Exceptional locations, which have "good optical paths" (because of the Fresnel effect this means better than line-of-sight) will have signal strength approaching the "free space" curve. Locations which are at grazing incidence or "lightly shadowed" will generally receive signals close to the solid curve. Locations which are deeply shadowed will have signals ten to fifteen db below the solid curve. However, for flat or gently rolling country the curve will be a good median.

The importance of this is that it means that in flat terrain the F(50,50) curves can safely be used to estimate the effect of power and antenna height on station coverage. This, in turn, may be very important in selecting a station site. Of course, it must be remembered that the curves will, at best, delineate the outer boundary of coverage. If there are any deeply shadowed areas within this boundary they will have to be investigated by other methods. And, most likely, the population living in these areas will have to be subtracted (from the total within the outer boundary) when making a count of total population served.

FIG. 6 (right). Reproduction of Fig. 5 of the Federal Communications Commission's "Sixth Report and Order". This is the F(50,50) Table referred to in the article. Technically, it shows the "Estimated Field Strength Exceeded at 50 Per Cent of the Potential Receiver Locations for at Least 50 Per Cent of the Time at a Receiving Antenna Height of 30 Feet". The FCC used this table in determining the "Table of Assignments" for Television Broadcasting Stations.

The solid curves shown in Figs. 2, 3, 4 and 5 were drawn by using values obtained from this table and corresponding to the height of the station antenna and the power radiated. According to the principle, this curve should be the median of the measured points. Within an approximation, and with certain reservations noted in the article, this appears to be true.

### Warning

We feel that UHF coverage reports to date give every reason for optimism regarding the quality of the service which will be provided by UHF television stations. However, in order to avoid disappointments it seems desirable to add a note of caution. This can best be done by pointing out several things which have not been "proved" by the present operations.

First, is the question of what happens at distances beyond 35 or 40 miles, i.e., well beyond the horizon. Will the F(50,50) curves be equally good? At present we don't know.

Second, there is some evidence that the F(50,50) curves may not be equally good at very low and very high antenna heights. Our data is confined to heights between 400 and 1000 feet. We have a feeling that below 400 feet the performance will fall below the F(50,50) curves—may, in fact, be quite disappointing. Conversely, above 1000 feet it may be better than the curves would indicate.

Third, the specified method of calculating "height above average terrain" may lead to a fallacious conclusion. This is because the "average terrain" on which the calculation is based is that between two and ten miles from the transmitter. This part of the path may be flat and low, lead-

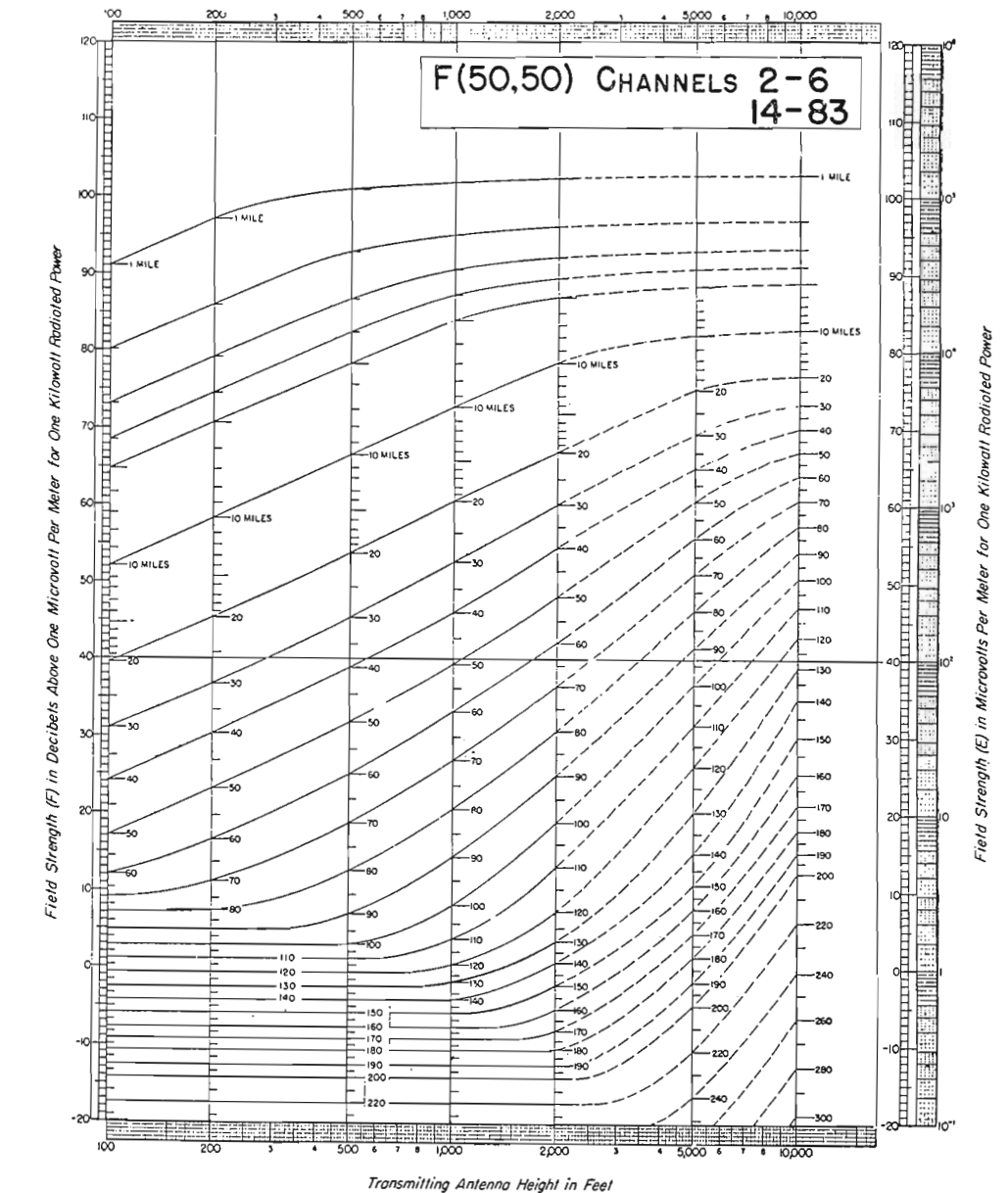

ing to a satisfactory antenna height. If the terrain along the path beyond ten miles is equally flat, then the curve corresponding to the calculated height may be used to estimate the service contours beyond ten miles. However, this may not be true. In the worst case there might be a high mountain ridge just beyond the ten mile point. If it were really high there would be no signal at all beyond it. Obviously the curve based on the two to ten mile terrain would be useless for predicting coverage beyond the ten mile point. A condition approaching this will often be encountered in mountainous country. Even in a terrain where medium-sized hills occur, it will often be a factor to be considered.

Fourth, there is the matter of shadows. Don't underestimate these. It has been pointed out that at Portland there are completely dead spots within two miles of

the transmitter. This can happen anywhere, if the hollows are deep. And, at present, we don't know whether any power—even 1000 KW—will bring the signal up to usable in these spots. It will in some, of course, but in others it's very doubtful. The moral, of course, is to do everything possible to get the antenna high enough to look into these hollows.

Fifth and finally, the important thing to keep in mind is "service to people". Coverage of a large area is not important if the population is sparse. The highest available mountain top is often not the best location when coverage of the largest number of homes is the criterion. The place to start is with a map showing "distribution of population". The best site is the one that provides coverage to the most homes on this map—not the one that offers coverage of the largest area.

# television-WHAT AND HOW

By

RENE BRUGNONI\* and BEN ADLER\*\*

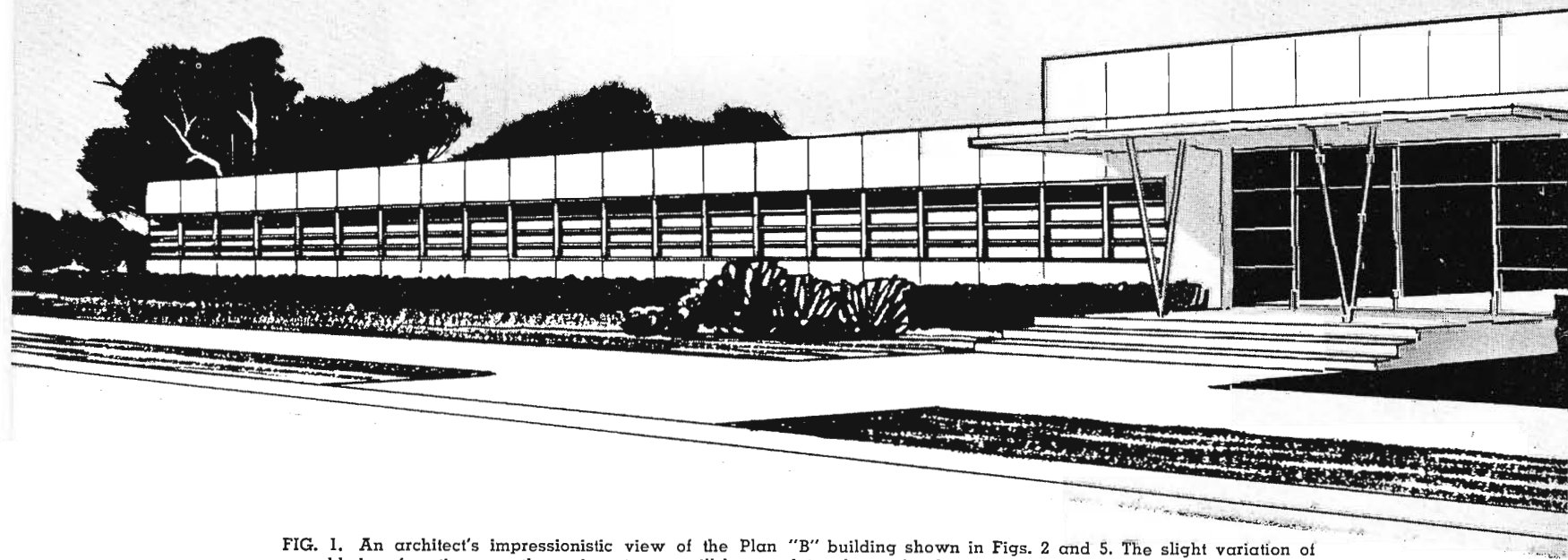

FIG. 1. An architect's impressionistic view of the Plan "B" building shown in Figs. 2 and 5. The slight variation of an added roof section over the main entrance will be noted in above sketch. Flexibility of the following plans makes them readily adaptable to individual construction requirements. Expansion of facilities to meet added stresses on traffic and operational levels, with a maximum of efficiency and a minimum of personnel, is a prime consideration. Note that if desired, the above building may be the result of logical expansion from Plan "A" and Plan "A-Prime" to Plan "B" as shown on pages 10 and 11. Considerable expense can be avoided by such progressive planning.

## ABOUT THE AUTHORS



\* Rene Brugnoni began his private practice as a registered architect in New York in 1934.

In 1944, he joined the American Broadcasting Company as architect in designing and planning of post-war facilities throughout the country, leaving in 1947 to set up his own practice. In all, since 1936, he has designed architectural

facilities for more than thirty-five AM, FM and TV projects, including WSM-TV, Nashville, WSYR-TV, Syracuse, WXEL-TV, Cleveland, and KPTV, the first U. S. UHF station, Portland, Oregon.

In his private practice he is now specializing in all branches of broadcasting with projects under way both in this country and abroad.



\*\* Ben Adler joined RCA in 1928 at the Van Cortlandt Park Research Laboratories in New York. In 1944, he became chief facilities engineer for the American Broadcasting Company in which capacity he played a major role in planning and developing ABC's post-war facilities for AM, FM, TV.

In 1947, he organized his own consulting en-

gineering practice in the AM, FM and TV fields. In addition to the engineering and construction of a number of AM and FM stations. Adler Communications Laboratories built WXEL-TV, Cleveland; WSM-TV, Nashville; WSYR-TV, Syracuse and recently completed the first commercially-licensed UHF Television station in the United States—KPTV, Portland, Oregon.

# TO BUILD

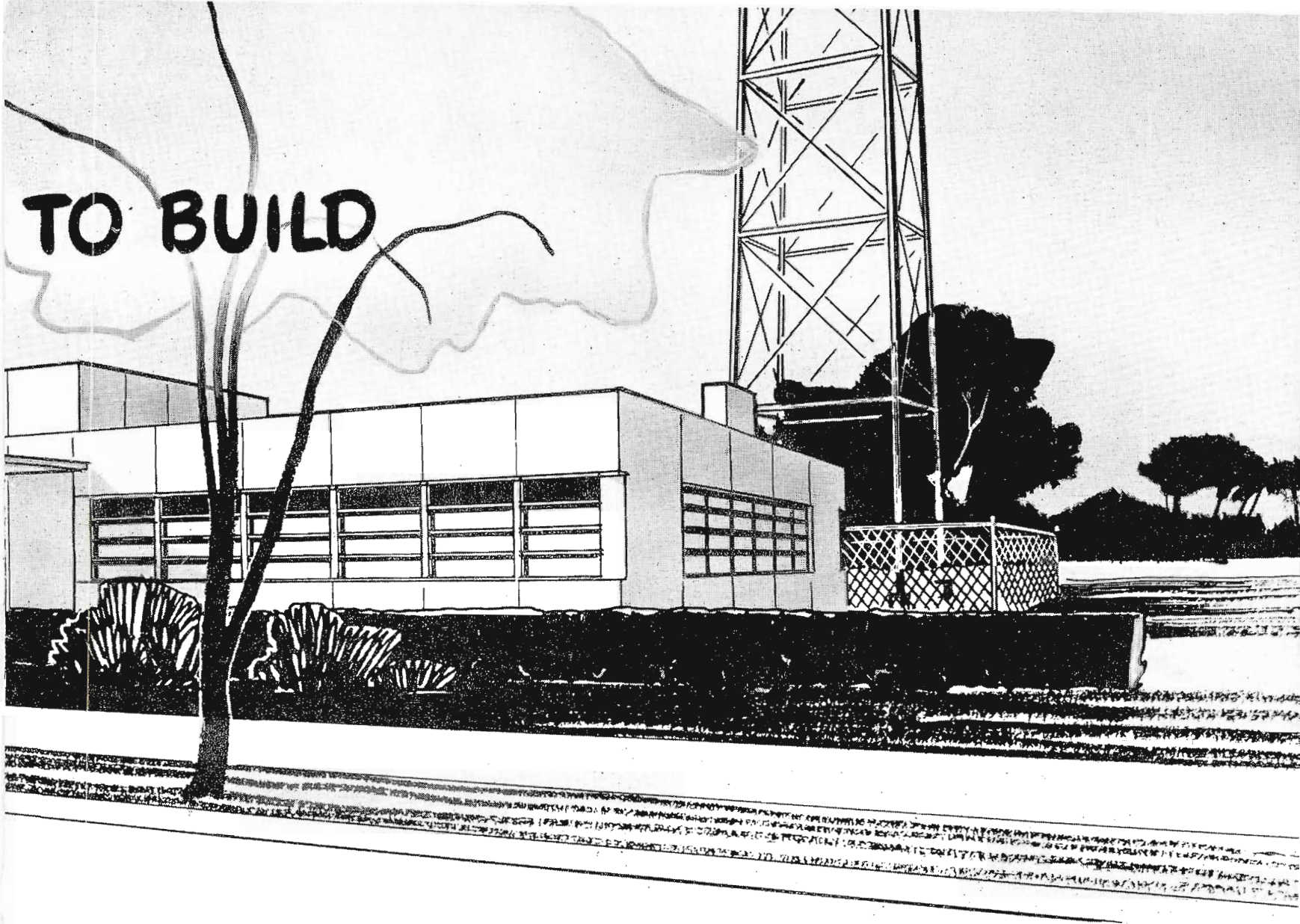

With the lifting of the freeze on Television station construction and the forecast of a number of new stations in operation by the close of 1953, the question of *What to Build and How to Build* is uppermost in the minds of many groups anticipating the grants of TV construction permits.

## Careful Planning Is Essential

No one element may prove more costly and frustrating to the prospective Television station operator than a "hurried design" intended solely to "get him on the air". Careless and haphazard methods of expansion can prove much more costly, in the long run, than the designing and building of an entirely new station that is created by careful planning.

Such thoroughness in the early planning

of a TV station is vitally important, not only because of the high total building and equipment costs, but also because of the definite need to provide for expansion in this growing art. How to expand facilities to meet added stresses on traffic and operational levels, with a maximum of efficiency and a minimum of personnel, is the problem.

Now is the time for considered thought before ultimate commitment in a project as costly and fluid in requirements as that of a Television station. In this article, an attempt is made to present and analyze with illustrations and descriptions a series of TV station building designs planned for *constantly increasing service*. Each of the designs presented is based on practical experience gained in the design, engineering

and construction—supervision of the facilities and operational systems of many TV stations now in daily operation.

## Four Classes of Operation Considered

Sufficient operating "know-how" has now been accumulated in commercial TV broadcasting to permit fairly accurate estimates of new station technical equipment and housing facilities for various classes of operation known to the art. Since a comprehensive study of TV station operating costs has already been published (see BROADCAST NEWS No. 68, pages 50-54 and BROADCAST NEWS No. 69, pages 24-37) for various classes of practical operation, these same general "class" groupings or divisions are considered here from the "housing facilities" standpoint. It is the

purpose of this article to further elaborate on data previously published and fully present typical facilities and building layouts for each class of TV station operation (see the table at right). From the viewpoint of technical equipment only, the requirements of "Station Group A" compare almost exactly with those of the RCA "Basic Buy" described in BROADCAST NEWS No. 66 and by descriptive bulletin, Form No. 2J8257. The other groupings (A', B and C) are expansions of Group A to provide live studios, remote facilities and additional program sources as required.

Station Group	Bldg. Plan	Transmitter Power	Program Sources	Bldg.* Costs Estimated	Floor** Space Sq. Ft.
A	Fig. 3	1 KW UHF 2 KW VHF	Film, slides, net, no live	\$49,900	3,270
A'	Fig. 4	1 KW UHF 2 KW VHF	Above, plus simple live	64,000	4,300
B	Fig. 5	10-25 KW VHF 10 KW UHF	Above, plus larger single studio live	106,000	7,000
C	Fig. 7	25-50 KW VHF or 10 KW UHF	Above, plus two-studio live, & remote	465,000	31,000

\* Includes building services less furniture and furnishings.  
 \*\* For high ceiling space, estimates of floor space should be doubled.

#### Four Separate Building Plans Are Presented

A careful study of the "Housing Facilities" data presented here (four individual building layouts and plans) should assist the prospective TV broadcaster to determine in his own mind the class of station he proposes to build and operate, consistent with the market he expects to serve and the budget or appropriation from which construction costs and early operating costs will be drawn.

In arriving at the four plans presented in this article, the objectives listed below were considered mandatory:

- (a) To present building plans that would reduce possible TV planning errors to a minimum;
- (b) To provide the prospective TV station operator with practical plans and

information to develop facilities adequate for his needs during early stages of operation;

- (c) To provide, at the same time, plans that permit suitable expansion with a minimum of obsolescence as the station grows.

#### Group "A" Building Plan

The Group "A" plan which will provide for handling program sources consisting of networks, film, and slide with *no live shows* is shown in the drawing of Fig. 3. It will be noted that minimum space has been allotted to the various facilities and services required to operate this type of station.

The operating core (consisting of the combination transmitter-control room, the projection room and the announce studio)

is arranged with observation windows in the partitions to permit projectionist, announcer and control engineer to see each other at all times during operation. Such arrangement reduces the operating personnel to a minimum. Arrangements are included for convenient access to film editing and storage and to the workshop where maintenance and repairs will be made on various pieces of equipment.

The film editing and storage space is so located in the building layout that receiving and shipping of films can be handled without interference to operations. The program-production people, who are required to have access to film editing facilities, have their office space within convenient distance.

The general arrangement of all facilities within this Group "A" building has been

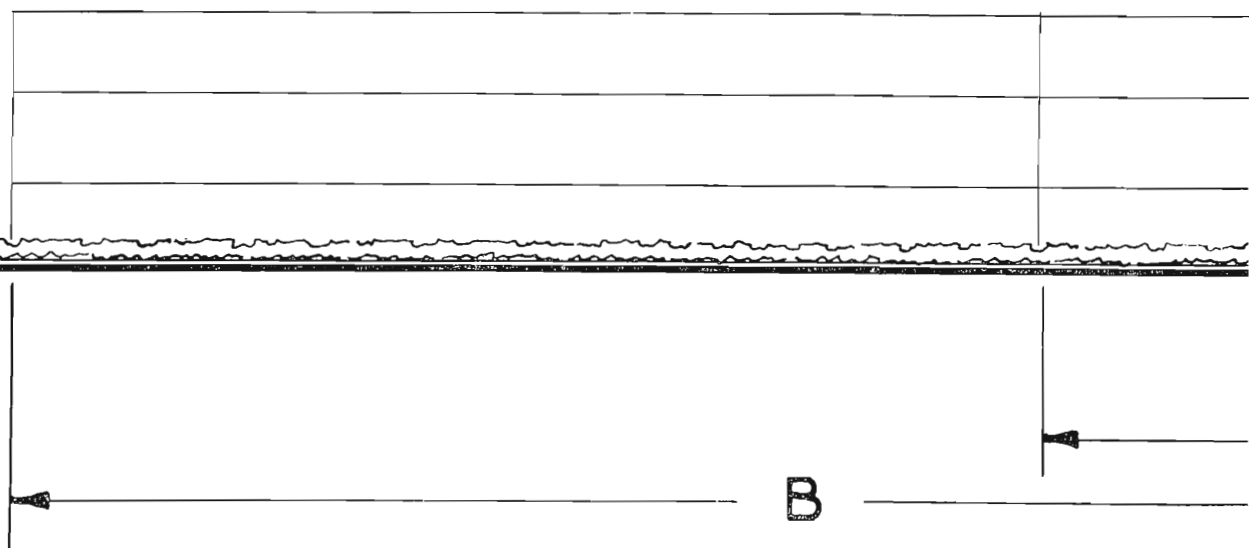



carefully planned to permit expansion to a Group "B" station. Fig. 5 shows a floor plan of a Group "B" station and upon careful inspection it will be noted that it consists essentially of the Group "A" plan with a large wing added to the left hand side.

**Group "A-Prime" Building Plan**

Before going into detail on the Group "B" plan, Fig. 4 (which shows a floor plan for a proposed Group "A-Prime" station) should be thoroughly studied. The "A-Prime" station provides for one small live studio with facilities for a single camera pick-up. The camera control for this single camera would be handled at the transmitter control console and would be operated blind.

The "A-Prime" station with a small studio of this type requires additional facilities for scenery and property storage, and working space for an artist to prepare scenic and allied effects. Absolute minimum space requirements for these additional facilities have been added in the Group "A-Prime" plan. This type of operation may prove quite attractive to the TV planner interested in low-cost operation,

**PROGRESSION DRAWING SHOWING ELEVATION PLANS "A" AND "A-PRIME" TO "B"**

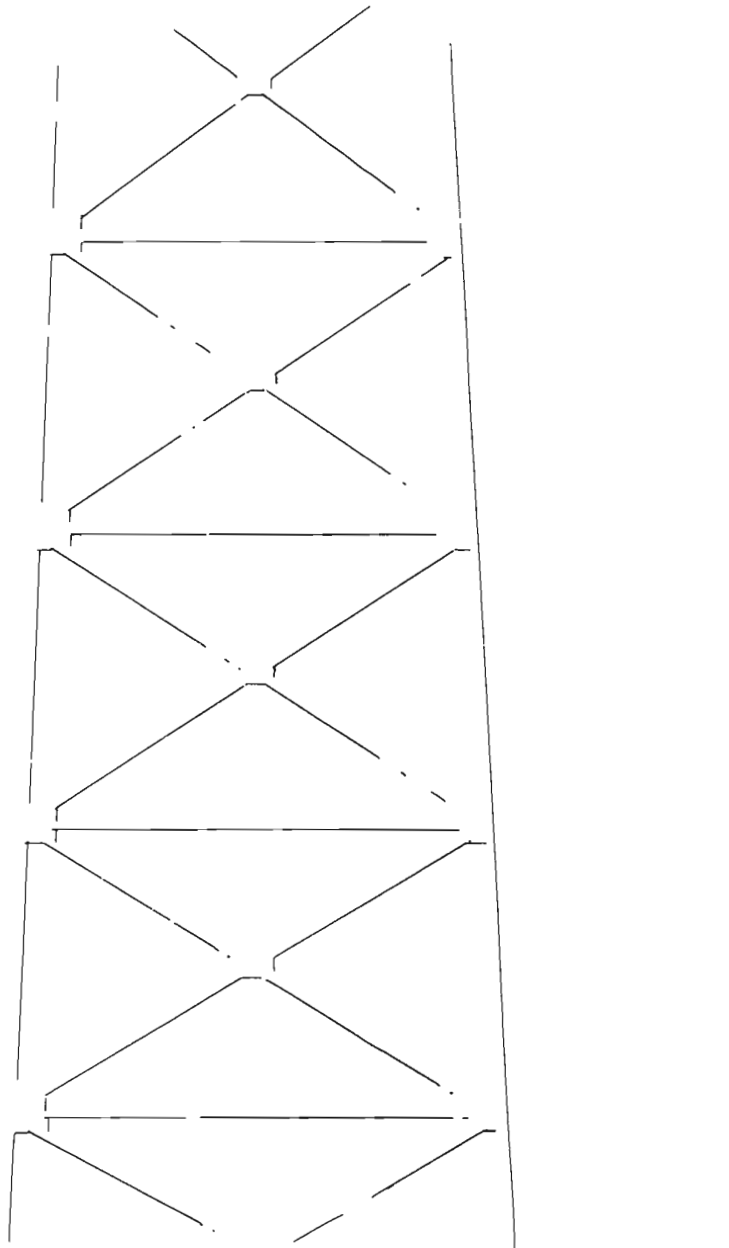
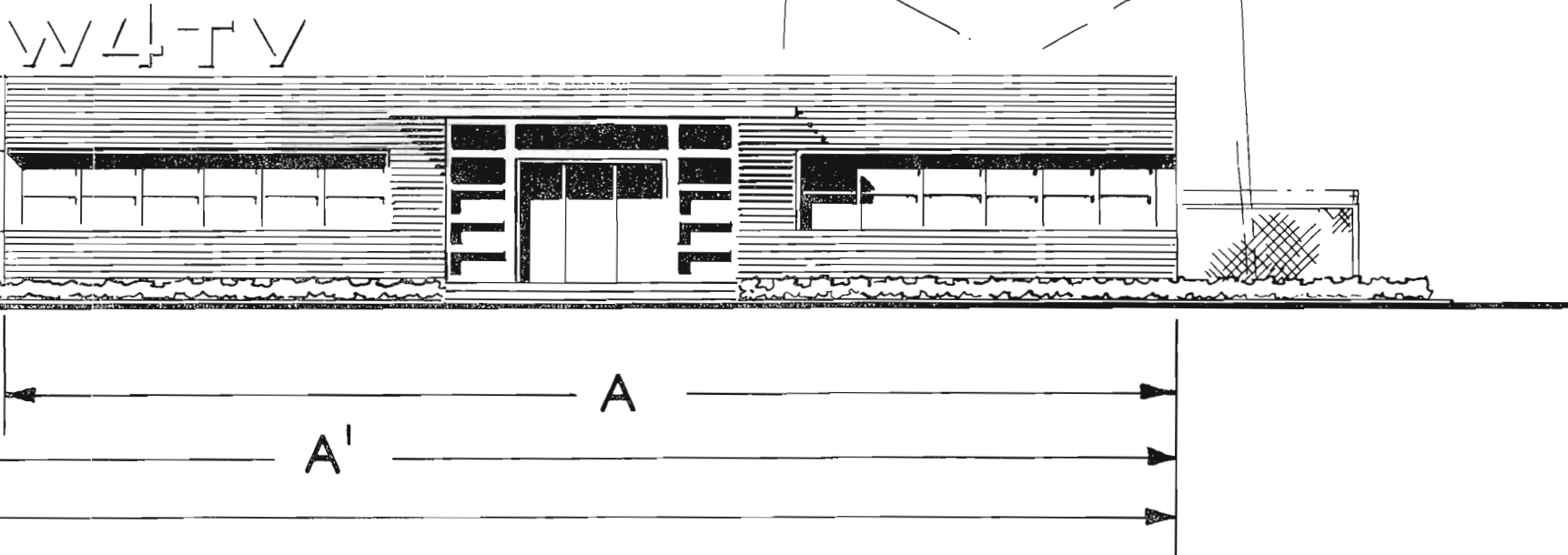

FIG. 2. Shown below is an architect's drawing showing the progression of three building plans—Plan "A", Plan "A-Prime" and Plan "B". Complete floor plans for each building are shown in Figs. 3, 4, and 5. Thoroughness in the early planning of a TV station is vitally important, not only because of the high total building and equipment costs, but also because of the definite need to provide for expansion in this growing art.



# GROUP "A" BUILDING PLAN

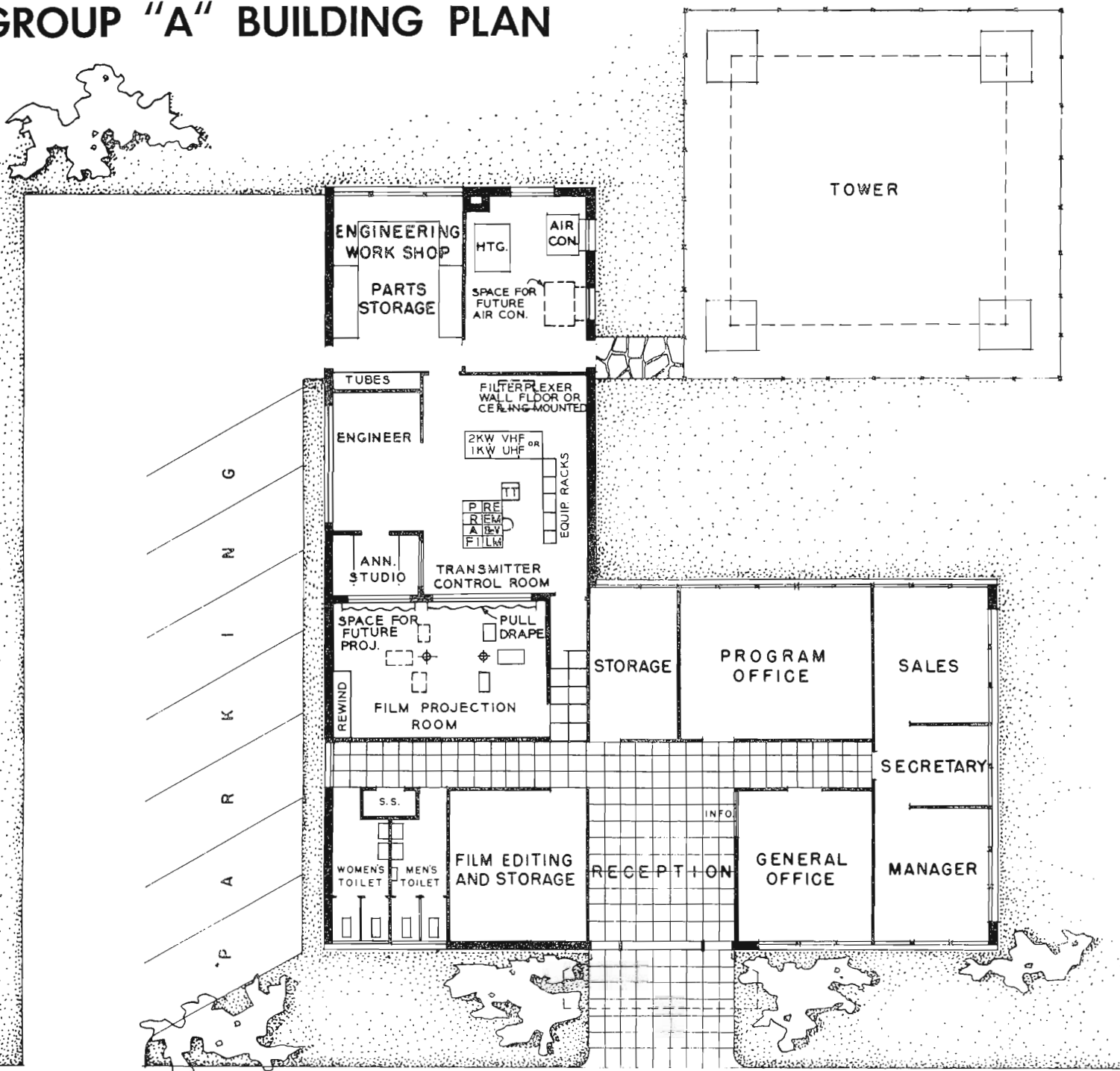

FIG. 3. BUILDING PLAN "A"—Accommodates a 1-KW UHF or 2-KW VHF Transmitter with program sources providing film, slides, and network programs but no live camera facilities. Estimated building cost for Plan "A" is approximately \$50,000.

# GROUP "A-PRIME" BUILDING PLAN

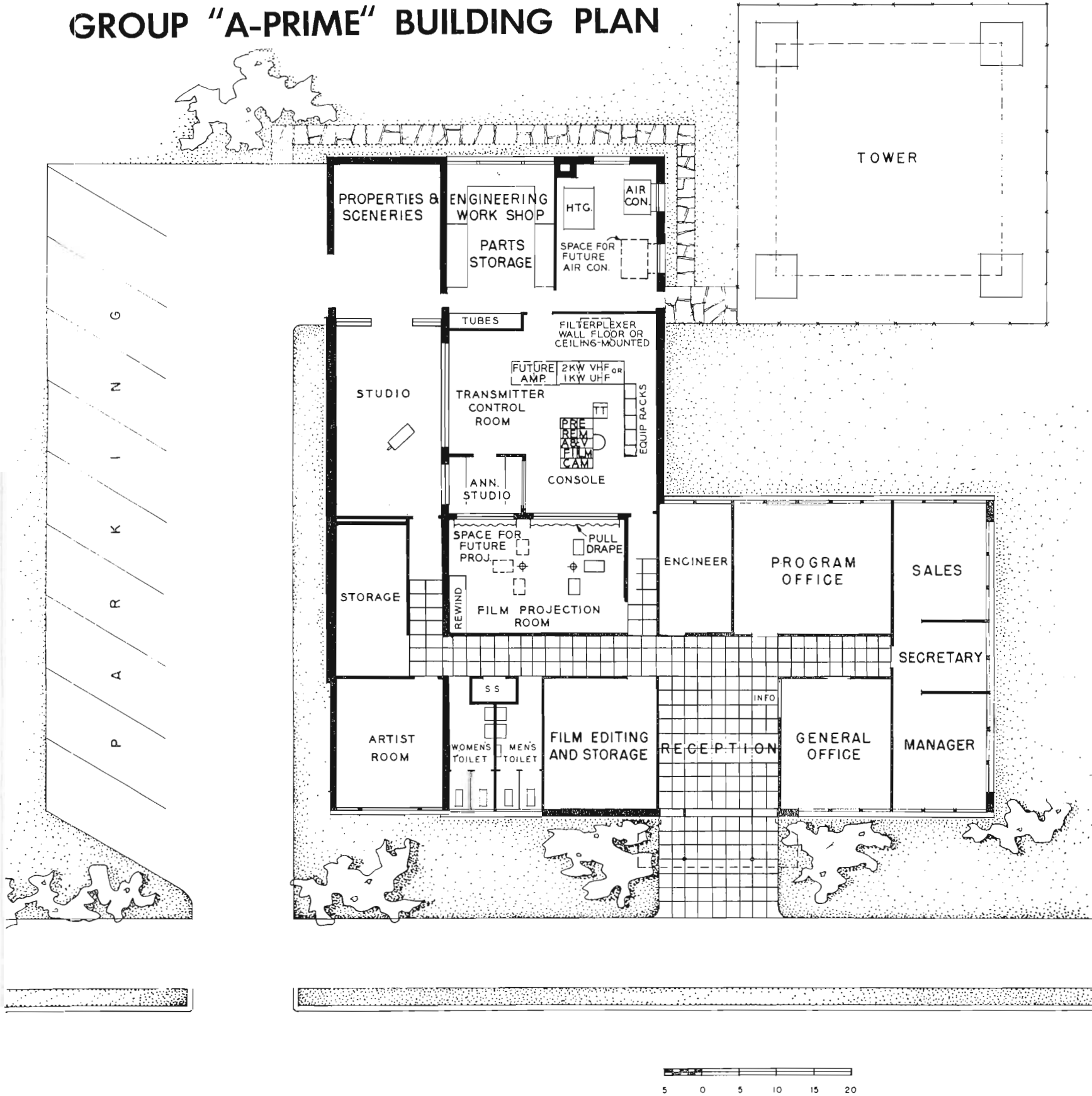
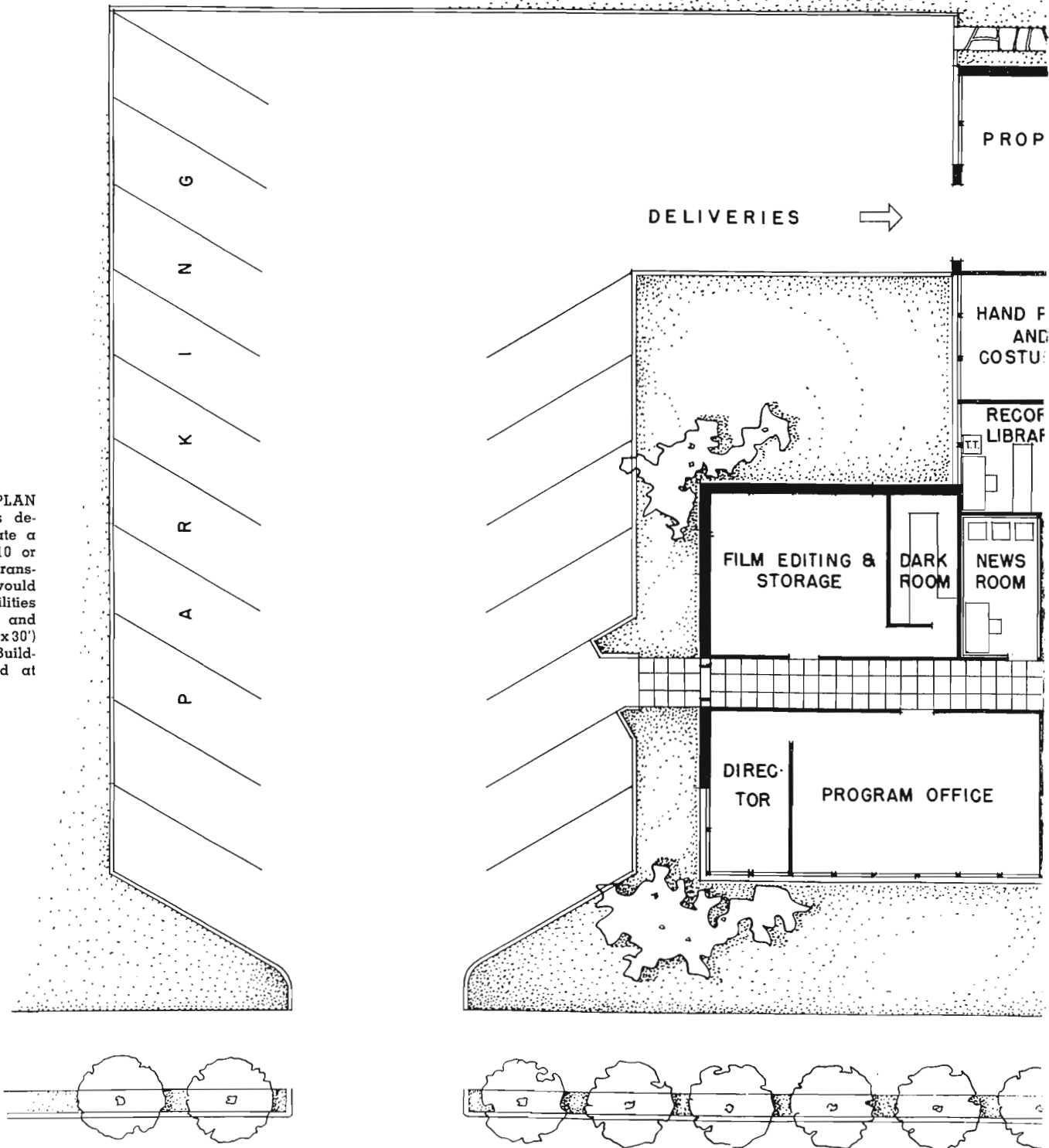

FIG. 4. BUILDING PLAN "A-PRIME"—Accommodates a 1-KW UHF or a 2-KW VHF Transmitter with facilities provided in Plan "A" plus a single camera chain and small studio. This building accommodates RCA's "Basic Buy" Television Equipment Package. Estimated building cost for this plan is approximately \$64,000.

# GROUP "B" BUILDING PLAN

FIG. 5. BUILDING PLAN "B"—this building is designed to accommodate a VHF Transmitter of 10 or 25 KW or a UHF Transmitter of 10 KW and would provide all of the facilities outlined in "A-Prime" and a moderate-sized (38'x30') two-camera studio. Building cost is estimated at \$106,000.



yet also interested in the extra revenue available from a single live-camera studio.

It is not felt, at this time, that the additional cost of construction and necessary equipment can be justified in stepping up from a Group "A" station to a Group "A-Prime" station. The Group "A-Prime" plan is offered as an alternate "initial construction only." A careful study of pro-

gram requirements should be made prior to the start of construction so that it will not be necessary to bear the extra construction expense of a simple, one-camera live program source at a later date.

The logical expansion of buildings would be from either a Group "A" plan to the Group "B" or from a Group "A-Prime" to the Group "B".

In preparing detailed architectural and engineering plans for either the Group "A" or Group "A-Prime" station, extreme care should be given to the design of the left hand wall of the building to simplify and facilitate the addition of the new wing for conversion to a Group "B" station. Also, provision should be made for land and suitable space for this expansion. For in-

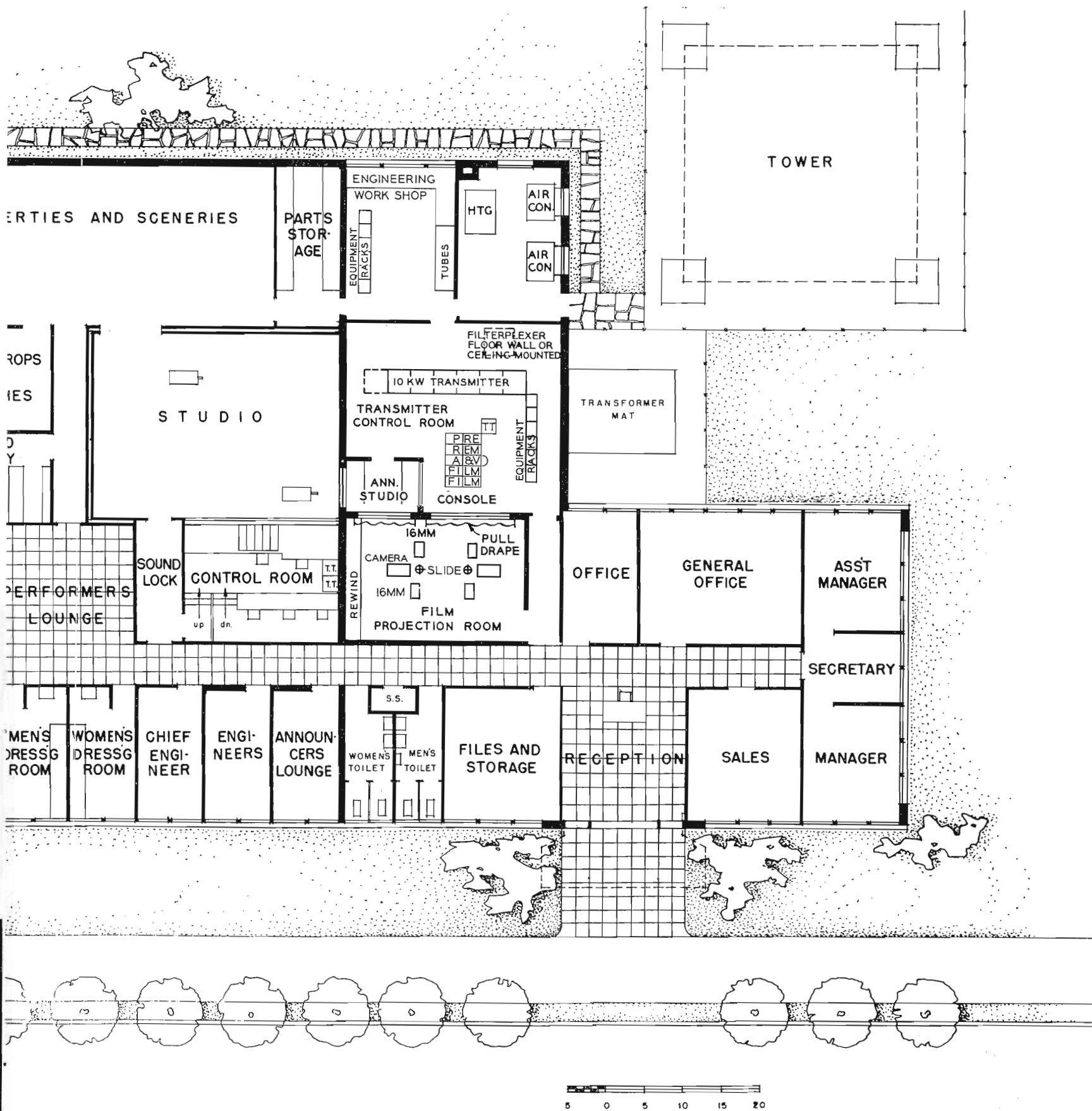

stance, it would not be wise to invest too much money in a paved parking lot where a new wing is to be added. This applies also to driveways, shrubbery, building service entrances, and other obstructions that may require removal when a wing is added.

#### Group "B" Building Plan

Referring to Fig. 5 showing the Group "B" plan, it will be noted that the an-

nounce booth and projection room remain the same as "A" and "A-Prime" except that an additional film camera is added. The transmitter control room is enlarged by eliminating the engineers' office and absorbing that space into the transmitter room so that a transmitter of up to 10 kilowatts may be used. A transformer mat is added outdoors to provide the necessary

incoming power facilities for the larger transmitter. It should be noted that the space originally allocated to heating and ventilating in the Group "A" plan is sufficiently large to permit the addition of extra heating and ventilating equipment in the Group "B" plan.

The program office of the Group "A" plan is moved to the new wing so that it

# GROUP "C" ELEVATION PLAN

will be closer to actual production operations, with the vacated space assigned to general office use. The same applies to the film editing and film storage space of the Group "A" plan which is relocated to provide easy access for shipping and receiving films and, also, to provide a suitable dark-room for quickly converting advertising copy, artwork and news pictures into slides suitable for projection "on-the-air" or for rear screen scenery projection. The added wing, which provides facilities for a Group "B" station, includes a good-sized studio with the necessary property and scenery storage space and extra offices needed for the enlarged operation. The new studio has its own control room which permits rehearsals to be carried on while the station is on the air with film, network, or a remote pick-up.

With only one studio added, the transmitter control room facilities remain almost the same as in the Group "A" plan. The large increase in master control facilities becomes necessary only when more than one live studio is included.

It should be carefully noted that the floor space requirements for the wing consisting of the studio, its control room, and the auxiliary facilities required to back up the studio with the enlarged operation is considerably larger than the entire original Group "A" station floor space requirements.

Several stations throughout the country made the very grave error of attempting to add a single studio to their original non-live pick-up operation without adding the auxiliary space required for the studio's operation. The stations found themselves using studio space for storage, props and scenery, actual making of flats and scenery, artwork, script writing, and rehearsals with only a small portion of the studio floor space available for live show production. The provision of space for adequate storage facilities where live shows are contemplated cannot be over-emphasized in planning a new station. This space cannot be made too large because unassigned space

can always be allocated to other uses as the need presents itself during the early growth of a new television station.

In checking back over the floor plans of Figs. 3, 4, and 5 (showing the space requirements for Group "A", Group "A-Prime" and Group "B" stations, respectively), it should be noted that space shown for office facilities can easily be expanded or contracted in the planning stage. The particular conditions under which personnel of a proposed station will operate determines the amount of space that will be required for the "front office". The plans presented include office facilities, produc-

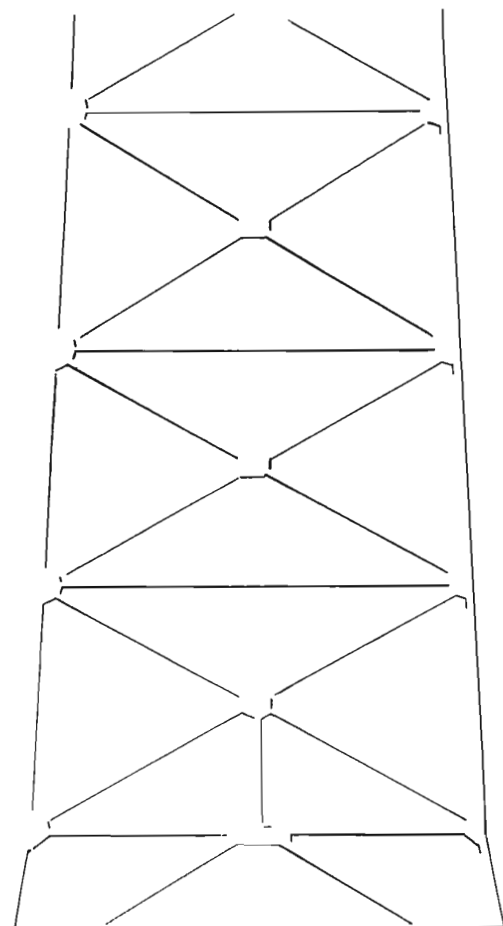
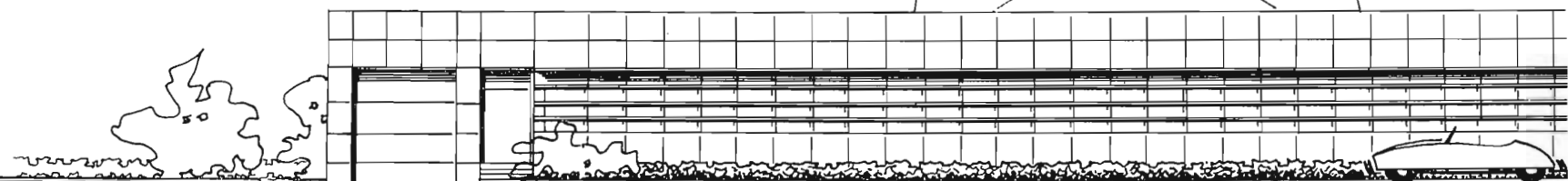

FIG. 6. ELEVATION PLAN "C", shown below by an architect's drawing, lends itself well to a large Television operation. It must be realized that an operation of the Group "C" type may have to accommodate as many as 100 people, including regular staff, performers and visitors. This flow of traffic without confusion and operational interference can be achieved only by modifying the rectilinear design into the building plan illustrated for Group "C".



tion facilities, and transmitter facilities—all in the same building at the antenna and tower site. There are many cases where the production and office facilities will be remotely located from the antenna and transmitter. Also, there may be instances where all facilities are combined under one roof at the antenna site except for sales offices.

With these facts in mind, the plans have been worked out so that separate parts of the suggested building may be selected and constructed separately, depending upon the operating conditions that are to be met. Just as important as providing space for the storage of props and scenery where live shows are to be produced is the provision of suitable space for performers. People who are to appear on television programs will arrive and depart from the station throughout the program day. Adequate parking space should be provided for artists and performers and, in addition, suitable dressing rooms and locker space where they may store their personal valuables. Extremely important, not only for the performers' comfort but also to eliminate interference with traffic and operations while waiting to go into rehearsal or on the air, is a suitable performers' lounge. It seems that many of the low cost TV programs with local interest involve large numbers of children, city, school and church officials and even animals and special props brought in at the last minute by performers. Space must be available for this type

of traffic and a well planned artists' lounge is considered to be the answer.

#### Group "C" Building Plan

The Group "C" plan has been designed for a more elaborate operation which probably can only be justified in a large market where a considerable amount of local program origination is contemplated.

The building layout for this group has been developed with operational requirements and traffic flow uppermost in mind. The same floor space probably can be achieved at lower cost within a square or rectangular building enclosure. However, this has been sacrificed to a small degree in the interest of traffic efficiency. It must be realized that an operation of the Group "C" type may have to accommodate as many as 100 people, including regular staff, performers and visitors. This flow of traffic without confusion and operational interference can be achieved only by modifying the recti-linear design into the building plan illustrated for Group "C".

Here again, the exact office space requirements will depend very much on the type of operation proposed; for instance, if sales activity is found to work more efficiently at another location, possibly closer to the center of town, the office space shown in the Group "C" plan may be reduced somewhat. The exact space requirements for general office, sales office, and other so called "front office" activities can only be determined after careful planning

by the station management and the architect involved in the project. The office space shown for operating requirements, which includes programming and engineering, should be adequate for the operating space shown in the plan. The Group "C" plan should be suitable as shown, even if the transmitter is located at a remote point out in the country or up on a mountain. A good portion of the control room space (which is shown as housing a 25-kilowatt transmitter plus master control) would be needed for master control alone.

The individual studio control rooms shown on the plan have been arranged in the conventional manner. The studio camera controls and audio equipment are located on the lower tier near the control room window. The director, video switcher and assistant director are on the upper tier, removed back from the control room window. This arrangement has been found satisfactory in many stations.

There is a trend, however, toward removing camera control equipment from the control room of an individual studio, and locating it in the master control room. Such an operational layout offers many advantages. First, it reduces the maximum number of operating personnel in the studio control room to three or, at the most, four if an assistant control room director or timekeeper is included. The basic personnel would be the director, video switcher and audio operator. The camera quality-control crew would be removed to master

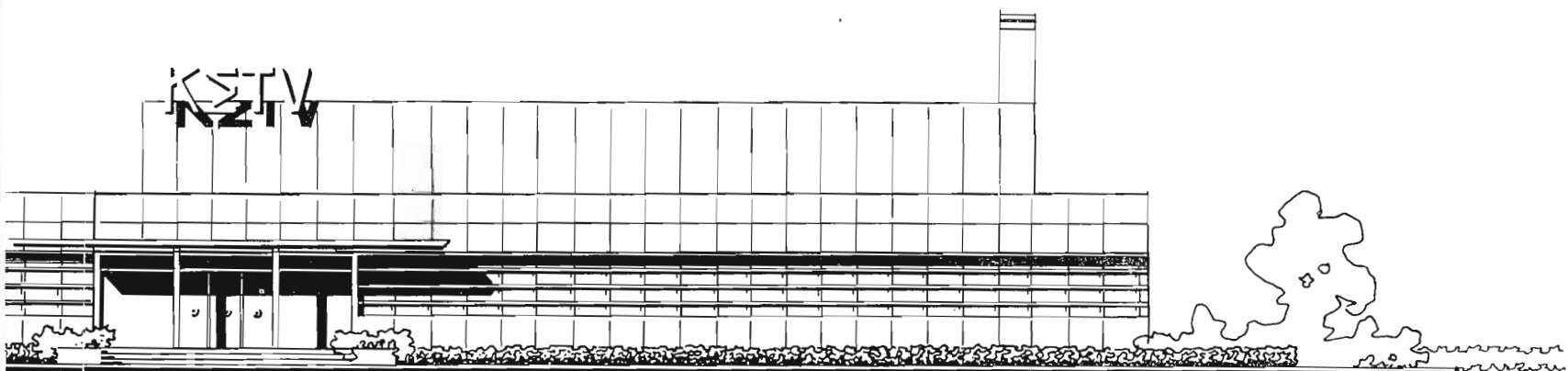

# GROUP "C" BUILDING PLAN

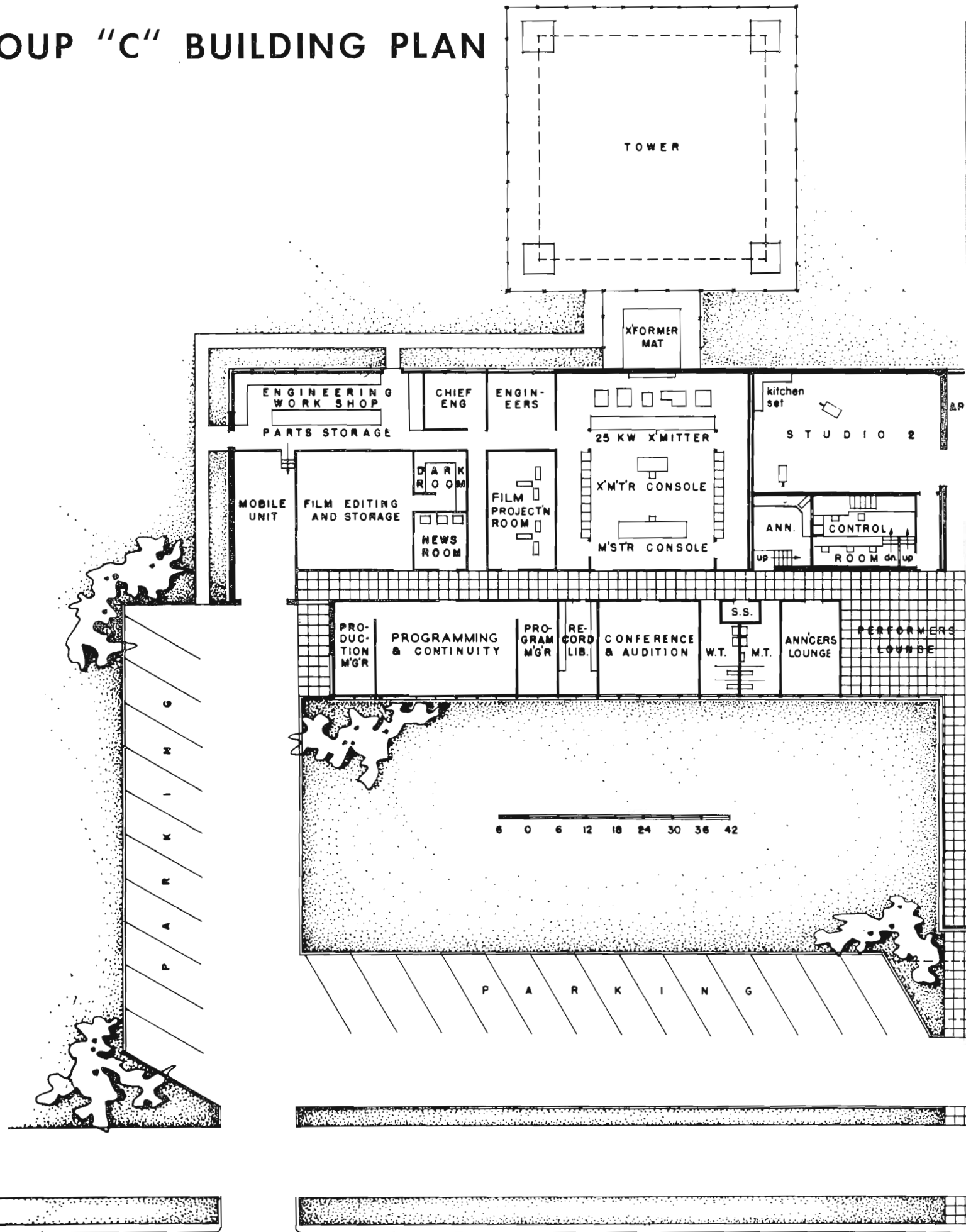
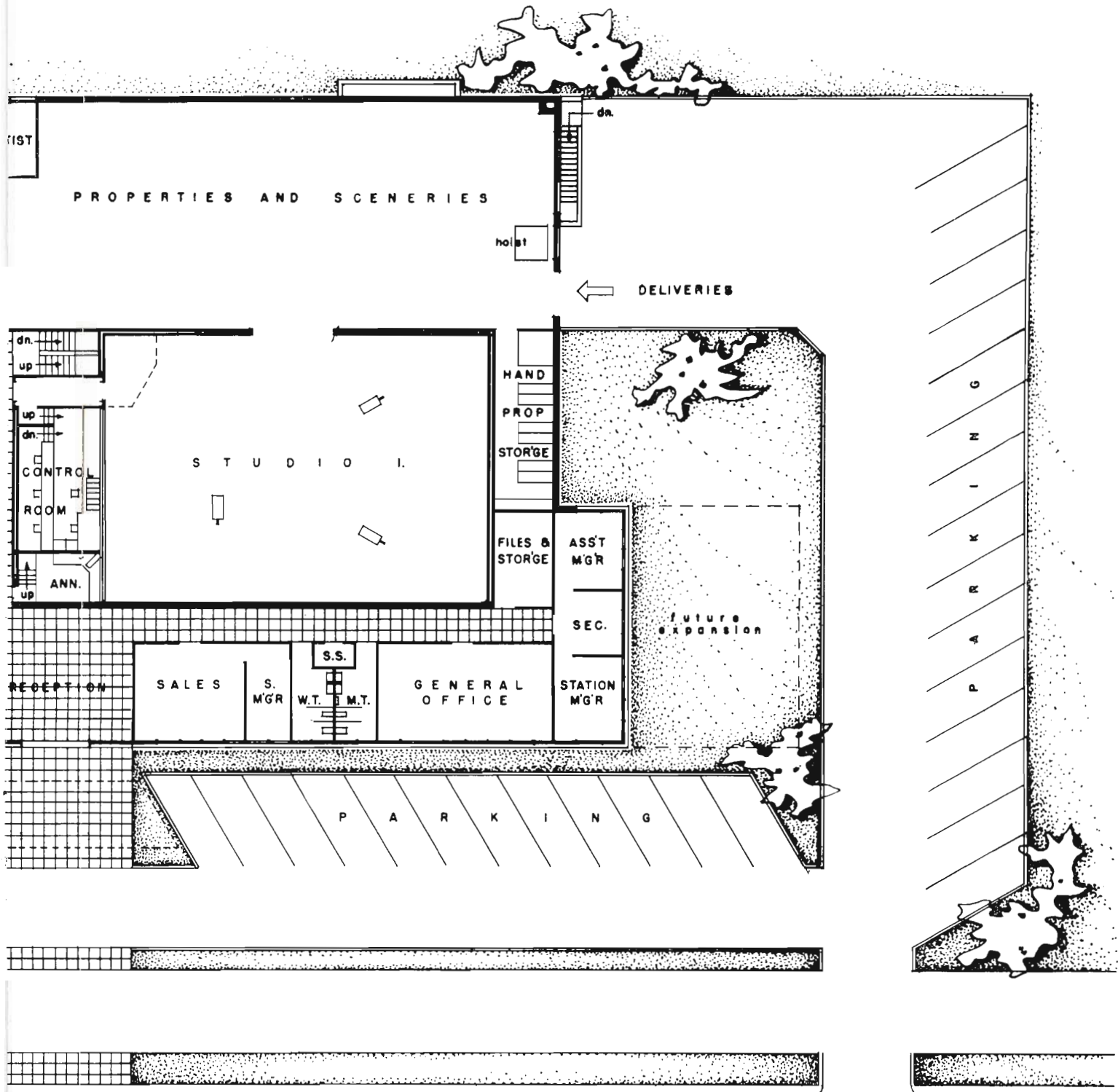
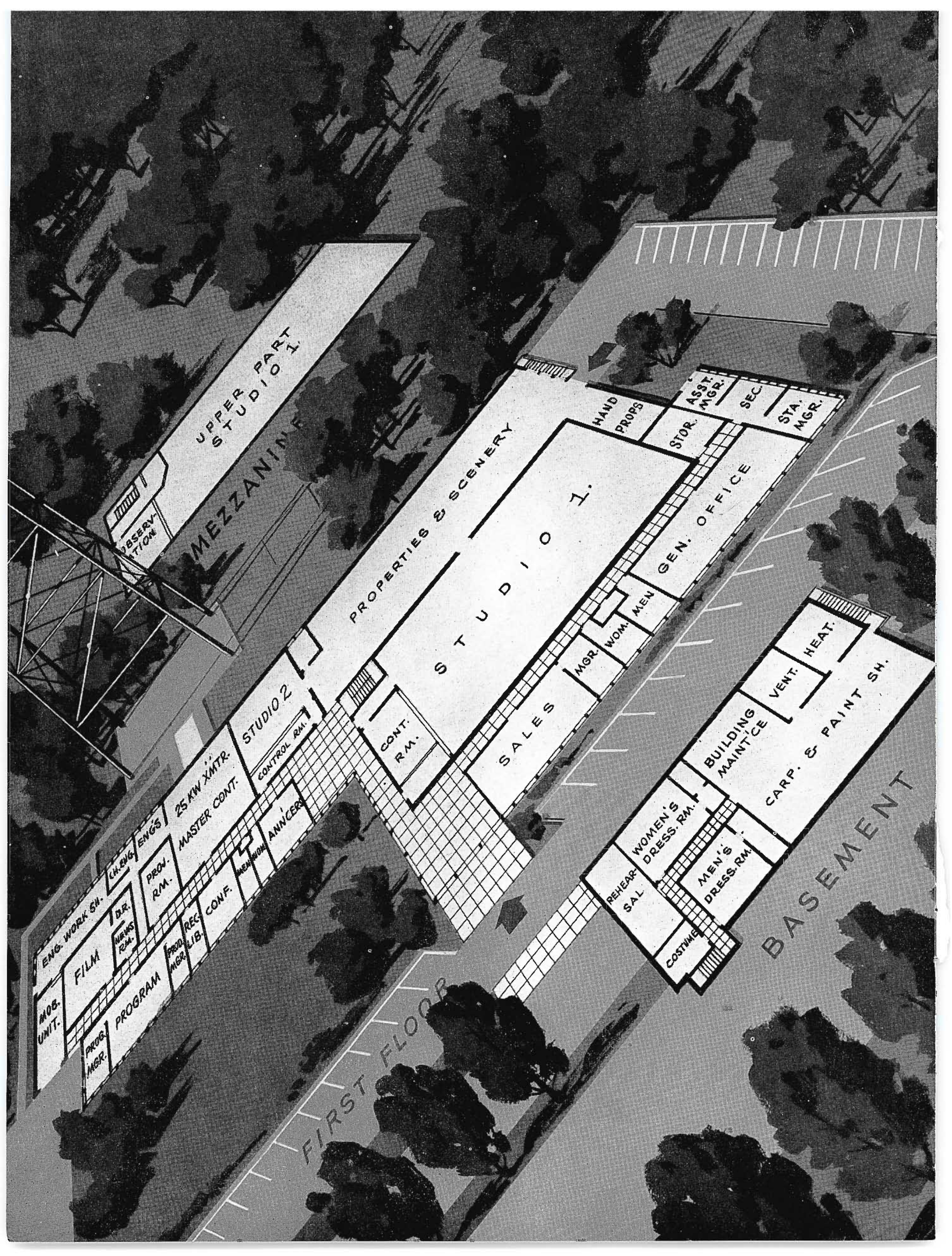



FIG. 7. BUILDING PLAN "C"—This plan covers a more elaborate operation which would probably employ a transmitter of 25 to 50 KW VHF or UHF and would provide all the facilities outlined in Plan "B" plus two, complete good-sized studios. Estimated building cost is \$465,000.





UPPER PART  
STUDIO I

MEZZANINE

PROPERTIES & SCENERY

STUDIO 1

HAND PROPS  
STOR.  
ASST. MGR.  
SEC.  
STA. MGR.

STUDIO 2

CONTROL RM.

25 KW XMTR.  
MASTER CONT.

ENG. WORK SH.  
FILM  
DR. NEWS RM.  
PROG. RM.  
PROG. MGR. LIB.  
CONF.  
ANNOUNCER  
MEN/WOM.

SALES

GEN. OFFICE

MGR.  
WOM.  
MEN

BUILDING MAINT/CE

REHEAR. SAL.

WOMEN'S DRESS RM.

MEN'S DRESS RM.

VENT.  
HEAT.

CARP. & PAINT SH.

FIRST FLOOR

BASEMENT

FIG. 8. Architect's conception of Building Plan "C" which is reproduced on the front cover in full color. This shows the three floor levels of the "C" building and their relative location and proportion.

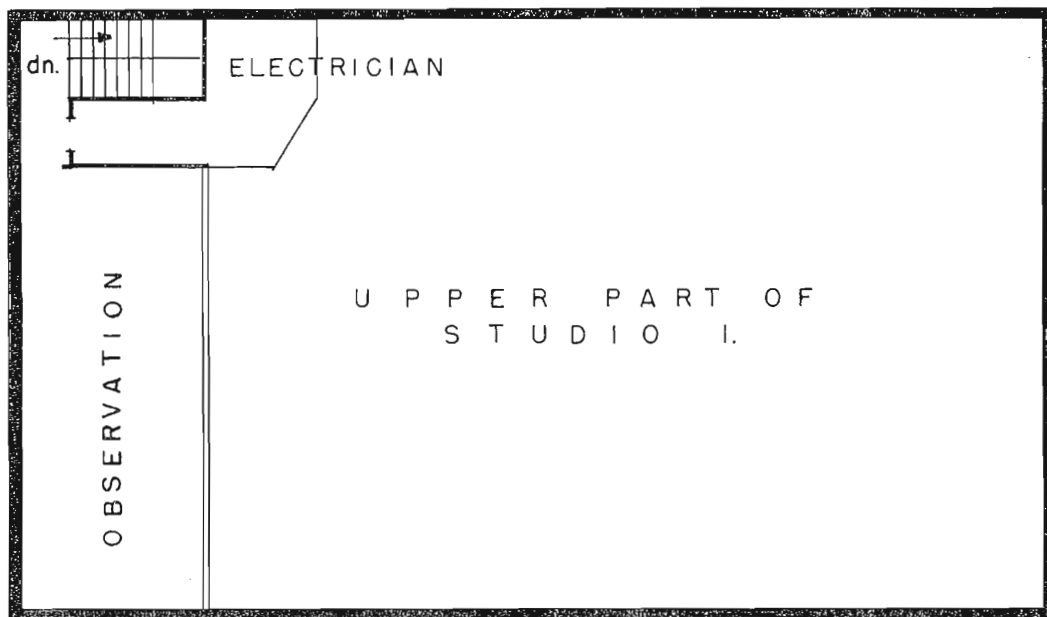

FIG. 9. Sketch showing upper part of Studio "One" which shows how this space may be used to accommodate clients' observation, electricians' quarters and lighting equipment.

control. Second, much of the heat-producing equipment, such as camera controls and, in some instances, power supplies, would be taken out of the studio control room. Third, repairs and adjustments in the event of failure of camera control equipment could be made more readily in master control than in the confined space of a studio control room. Fourth, the layout would reduce the size of the studio control room. Of course, this arrangement requires some additional equipment in

the form of picture monitors as extensions from the monitor contained in the camera control.

No attempt has been made in this report to go into a Group "D" plan which would involve a transmitter producing maximum ERP and more than two live studios with facilities for producing and feeding several different programs simultaneously. A Group "D" station would be almost entirely custom built and, for that reason, is considered beyond the scope of this report.

In writing this article, the authors hope that the information presented will be of value to prospective TV station operators in the vital planning stage. The article is intended as a guide to immediate needs, and a forecast of potential future development. Each TV station enterprise must appraise its individual potential at the outset and project its market possibilities and consequent demands on service for the future. Only in this way can economically successful TV operation become a reality.

FIG. 10. As shown in the sketch below, the basement level of Plan "C" is used to advantage in housing heavy heating and ventilating equipment, as well as providing additional dressing rooms, rehearsal and costume space.

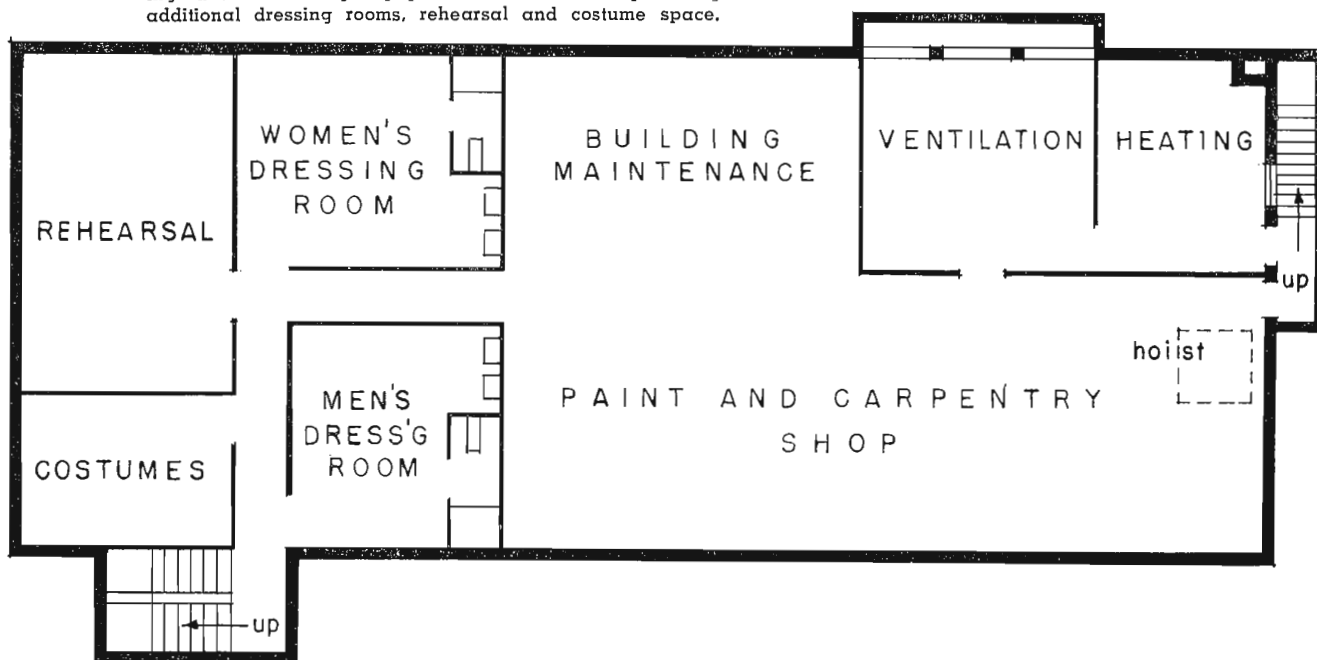



JOHN G. LEITCH, Vice President in Charge of Engineering, WCAU Stations. The preliminary plans for the new building were made by the WCAU Engineering Staff under his supervision. He also acted as owner's representative during the erection of the building which was designed and constructed by the Austin Company. George Howe and Robert M. Brown were the consulting architects.

# ↑ WCAU's NEW

## Philadelphia Bulletin Stations' New Studio Building Features Functional Design and Complete Integration of Radio and Television

By  
**JOHN G. LEITCH**

Vice-President in Charge of Engineering  
WCAU Stations

Thirty years of radio broadcasting and four years of regularly scheduled television programming were celebrated by WCAU with the opening of its new radio and tele-

vision center at City and Monument Avenues. A far cry from the small Market Street building where the station first went on the air in 1922, the new WCAU Center is also a considerable advance from its old location at 1622 Chestnut Street, which, when it was built in 1931, was the first building in the country to be constructed exclusively for radio. (See story in BROADCAST NEWS, Vol. No. 7, April, 1933.)

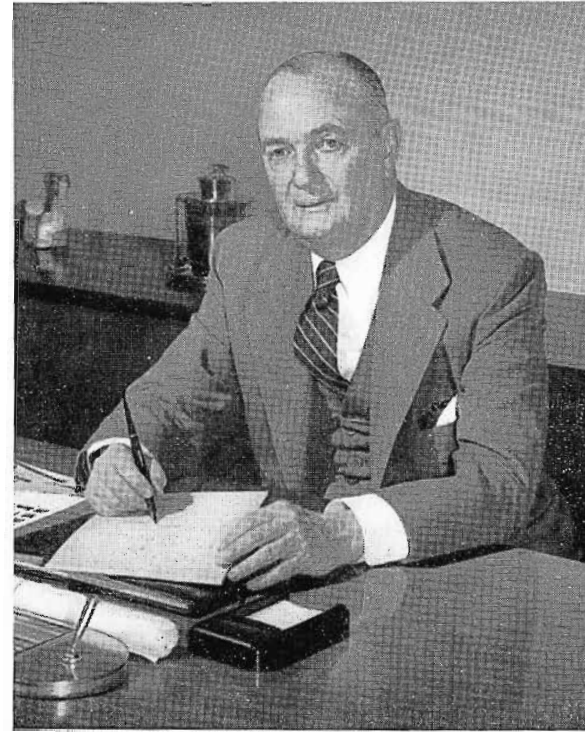

DONALD W. THORNBURGH, President of WCAU Stations, in his office in the new WCAU Building. Formerly CBS Pacific Coast Vice President, he joined WCAU in August, 1949. The expansion of WCAU's television activities and construction of the new building were carried out under his direction.

FIG. 1 (left). WCAU's new Radio and Television Center is an ultra-modern building 201 feet wide, 220 feet deep and the equivalent of three stories in height. The building is completely air-conditioned and is windowless except for the south and east walls of the lobby which are entirely of glass.

# RADIO & TELEVISION CENTER

It is interesting to note that in 1931, when the Chestnut Street building was under construction, plans were made to permit the adaptation of the building to television, which was then little more than a dream.

War halted construction of the WCAU experimental television station, which was started in 1939, but in September 1946 the Federal Communications Commission granted a TV construction permit to the station and the first test pattern was aired on March 1, 1948. Meantime, two studios in the Chestnut Street building were converted for TV operation and on May 23, 1948, WCAU-TV was officially inaugurated and began regular programs. Because of

the planning done 17 years before, the modifications were quite successful and within a few months WCAU-TV was one of the nation's foremost television stations.

However, the rapid expansion of WCAU-TV—which, incidentally, was one of the first affiliates of the CBS television network—naturally brought with it personnel and space problems, and within a year after it started regular programming it was beginning to encroach on the radio operations in the Chestnut Street building, eventually taking over two whole floors.

In spite of the space shortage, WCAU-TV became in four short years a leading station in the area, and even received nationwide recognition as a production center.

The station now has the distinction of being the third most active producer in the CBS network with six network originations. The description of the new building as "the World's Most Complete Radio and Television Center" is no mere publicity tag, for, at the present time, no other structure exists which houses as many modern facilities for radio and television broadcasting.

WCAU—whose record of public service, imaginative programming and talent discovery is unequalled in the Philadelphia area—maintained its status of "Pioneer-leader" with the opening of the new facilities which are described on the following pages.

# PLANNING THE NEW WCAU BUILDING

As soon as it became evident that much greater space would be required, WCAU began making plans for a new building. One of the first steps was a thorough and systematic survey of all television stations on the air. At that time no station had a plant which could be said to be the best in all possible respects. However, some good features were found in each of the stations visited and these were carefully noted. From these notes, and WCAU's own experience, which by then was the equal of any station on the air, there was drawn up a set of basic requirements to be met in planning the new building. These were:

First, it should be located in a suburban area, where sufficient ground for horizontal building and future expansion could be obtained at a cost which could be justified. The site should be readily accessible to personnel, to offices of agencies and sponsors in the Philadelphia area—to talent, people attending audience shows and the usual visitors to a radio and television station. Adequate parking space must be provided.

Second, the building must be primarily functional. It was believed that a functional building should include construction assuring efficient operation of air conditioning and heating, good lighting through-

out, well-planned individual departmental layouts and proper relationship among all departments of the organization.

Third, all operations should be on the ground level. Vehicles should be driven directly into all the TV studios and the storage area. Equipment and operating personnel should move about the studios and associated rooms without using stairs or elevators.

Fourth, space should be provided in small amount for quick expansion and the building and site should permit orderly expansion of some magnitude if future conditions should require it.

With these basic requirements in mind a ten-acre site at City Line Avenue and Monument Road was purchased in the summer of 1950. After preliminary plans had been made by the WCAU Engineering Staff, the Austin Company of Cleveland was selected to design and construct the new center. Austin Company engineers, working with WCAU staff members and George Howe and Robert M. Brown, architects, started work in October 1950. In January 1951, work was suspended for four months because of a shortage of controlled materials. However, in May 1951, work was resumed and went on without interruption until the building was finished.

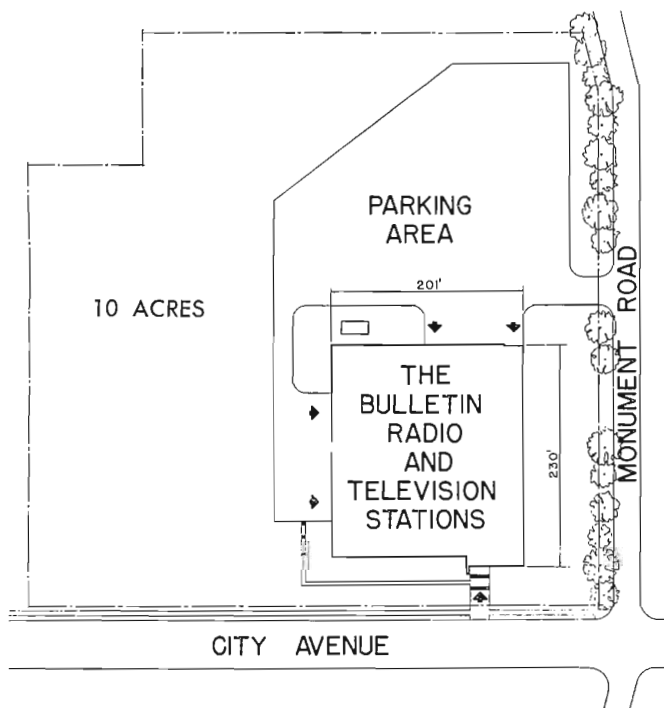
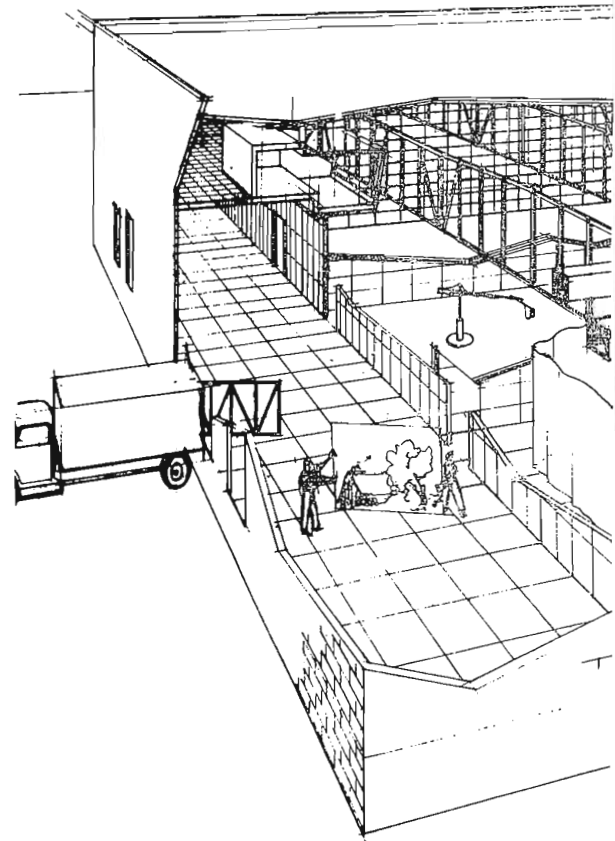

## LOCATION OF THE BUILDING

The center is located in suburban Philadelphia within easy reach of the city's major residential and business sections. It is six miles from City Hall (downtown Philadelphia)—a distance which may be driven in about twelve minutes under normal traffic conditions. Located on the north side of City Line Avenue at Monument Road, the studios are accessible to "out-of-towners" from U. S. Route #1 since City Line Avenue is a part of U. S. Route #1. The new Valley Forge Parkway, an extension of the Pennsylvania Turnpike, comes in from the north with a clover leaf turn-off to City Line Avenue within a half mile of the building.

The building property consists of about ten acres, has 600 foot frontage on two streets and is essentially square in shape. The building also is almost square with outside dimensions 201 by 220 feet.

FIG. 2 (left). In order to be sure of room for future expansion, as well as for parking, the WCAU building was located on a corner of the 10-acre site. The "Parking Area" which is in the rear of the building, is entered from Monument Road. Access is provided not only to the rear of the building, but also to the west side (lefthand in this diagram) so that trucks may be driven directly into the studio area. The manner in which it is planned to use an additional part of this tract for future expansion is indicated in Fig. 51 on Pg. 51. In the meantime, the back corner, which is wooded and includes a small stream, may be used occasionally as an outdoor studio.

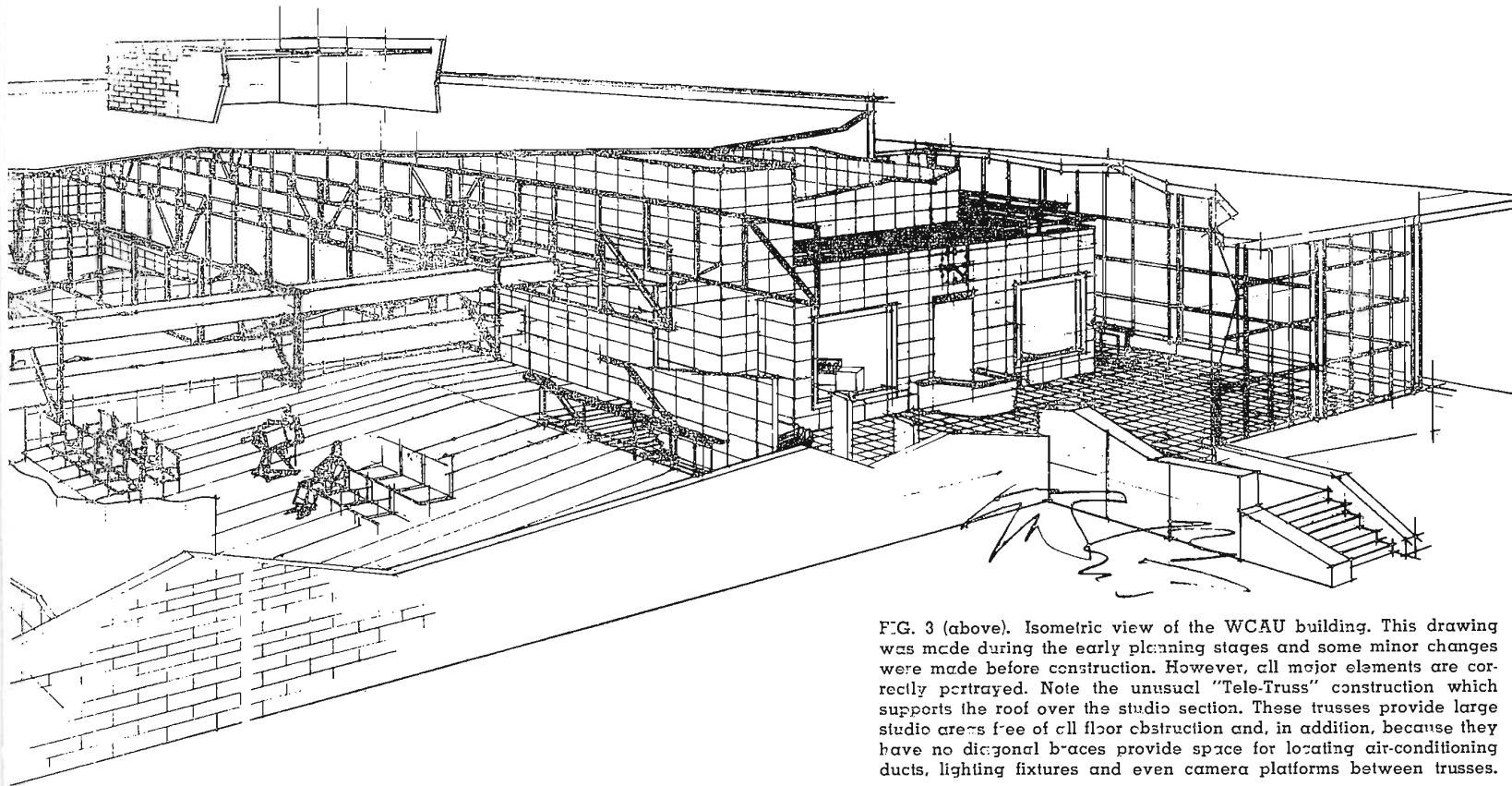

FIG. 3 (above). Isometric view of the WCAU building. This drawing was made during the early planning stages and some minor changes were made before construction. However, all major elements are correctly portrayed. Note the unusual "Tele-Truss" construction which supports the roof over the studio section. These trusses provide large studio areas free of all floor obstruction and, in addition, because they have no diagonal braces provide space for locating air-conditioning ducts, lighting fixtures and even camera platforms between trusses.

## GENERAL DESCRIPTION OF THE NEW WCAU BUILDING

In the design of the new WCAU building emphasis was placed on functionalism. However, the visitor approaching the building for the first time is not immediately aware of this. In fact, he is more likely to be a little awed by the size and impressiveness of the structure, and even to have a feeling that it is on the lavish side. It is a tribute to the skill of the architects that despite the austerity of detail they have been able, with simple lines, to achieve a sweep and beauty which is unusual in buildings of this type.

The most striking outward feature of the building is, of course, the immensity of the glass walls which stretch along half of the front and all of the right side of the building. A quick impression is that one half of the building is brick, and the other half is glass. And this is, in fact, approximately true. The building is actually built in two sections which are of quite different construction. The west section (lefthand in Fig. 1) contains the seven radio and television studios. It has solid brick walls without windows. The roof is supported by huge "Tele-Trusses" (Fig. 3) in order to provide 60 x 80 foot studios with high ceilings. Studio floors are poured directly on grade.

The east section of the building (right in Fig. 1) has all glass walls (except in the rear) and is of three-story construction. Control rooms, news room, and other operating areas are located on the main floor. Offices are on the second floor. Service facilities of all sorts, even including a cafeteria, are on the ground floor under this section of the building.

The most outstanding features of this building are: (1) the one-story production section which eliminates all vertical movement of equipment or props; (2) the self-contained "operational block" which can carry on full operation when the rest of the building is closed; and (3) the arrangement of separate corridors for visitors, staff and props which promotes easy traffic flow. These and other features of this interesting building are described in detail on the following pages.

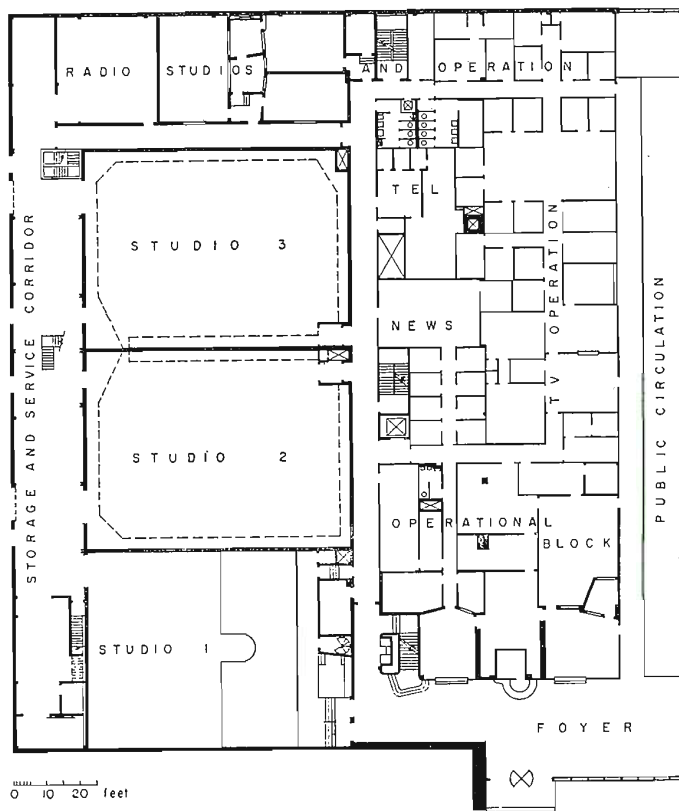
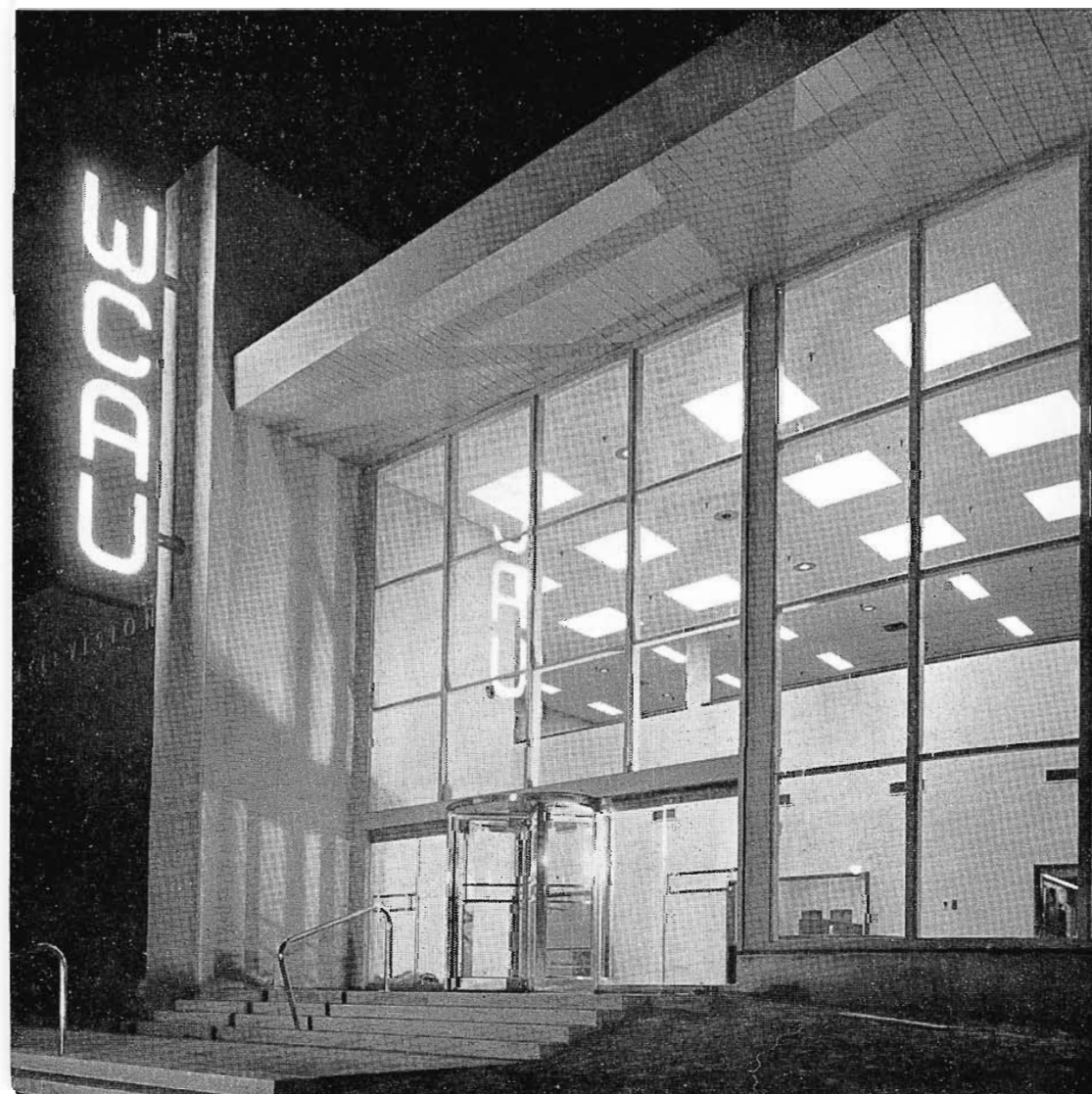

FIG. 4. Main floor plan of the WCAU Radio and Television Center. The four TV studios and three of the four radio studios occupy the left section of the building. In this section there is also a large "storage and service" area which runs the length of the building at the rear of the TV studios. TV Studio 1 has an audience seating area which is entered directly from the foyer. The other studios are entered from the center corridor. The right section of the building is three stories in height. The main floor, shown here, provides space for control rooms, announce studios, news and transcription rooms and program and production offices. Business offices are located on the second floor while service shops, dressing rooms, cafeterias, etc., are on the ground floor beneath this section of the building.



FIG. 5 (above). The front of the WCAU building as it appears from City Line Avenue at night. The center door (see closeup below) leads directly into the glass-enclosed two-story lobby. Although the WCAU building is primarily functional in design, with emphasis on simplicity of lines, the spaciousness of the lobby gives a feeling of grandeur which is in keeping with the size of the overall operation. The reception desk and telephone board are directly opposite the door. At the left of the reception desk (behind the revolving doors in this view) is the window looking into the AM Master Control Room. At the right of the desk (the dark window at right center in this view) is the window of the TV Master Control Room. Above the reception desk and the control rooms is the second floor lounge which leads to the executive and business offices.



## ENTRANCE TO THE WCAU BUILDING

The main entrance to the Center is on the south side on City Avenue and enters directly into the glass-enclosed two-story lobby. From the lobby, the south and east glass walls provide a fine view of the Schuylkill Valley and the river's east bank. One of the highlights of the lobby is the Radio and Television Master Control Rooms which are located on either side of the reception desk and whose equipment and operations can be viewed through floor-to-ceiling plate glass window.

The public entrance at the north side faces, and is on a level with, the parking lot, and a ramped corridor (see Fig. 8), which runs the full length of the glass-enclosed east side of the building, connects this door with the lobby on the main floor. This entrance arrangement, with a ramp from the parking lot, brings all passenger traffic to the main lobby for control by the receptionist at the desk adjoining the PBX.



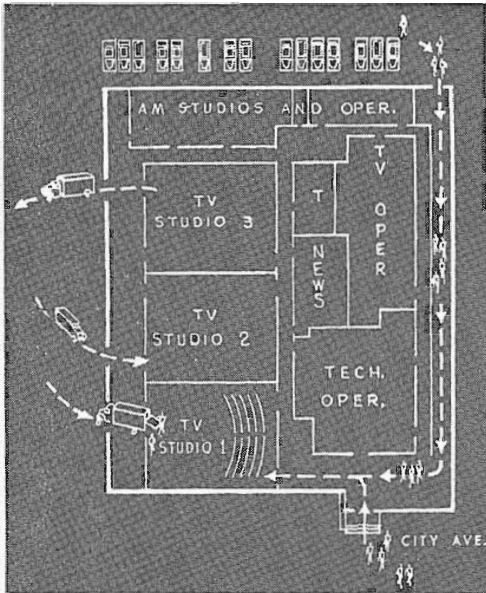

FIG. 6 (above). Planning of traffic is indicated by this diagram. The public may enter the lobby directly from the front, or may come in the rear door from the parking lot and up the ramp to the lobby. Audience shows are ordinarily handled in TV Studio 1, which is entered directly from the lobby. Meantime, props and scenery are brought directly into the stage areas of the three TV Studios by the large ground level doors at the west side of the building. A more detailed traffic plan is shown in Fig. 14 on Pg. 33.



FIG. 7 (above, right). Rear of the WCAU building as seen from the parking lot. Visitors parking cars in the lot may conveniently enter through the doors just under the WCAU sign. The garage at the right is for the TV Mobile Unit and field trucks.

FIG. 8 (right). Looking up the long ramp which leads from the parking lot entrance (Fig. 7) to the main lobby at the front of the building.

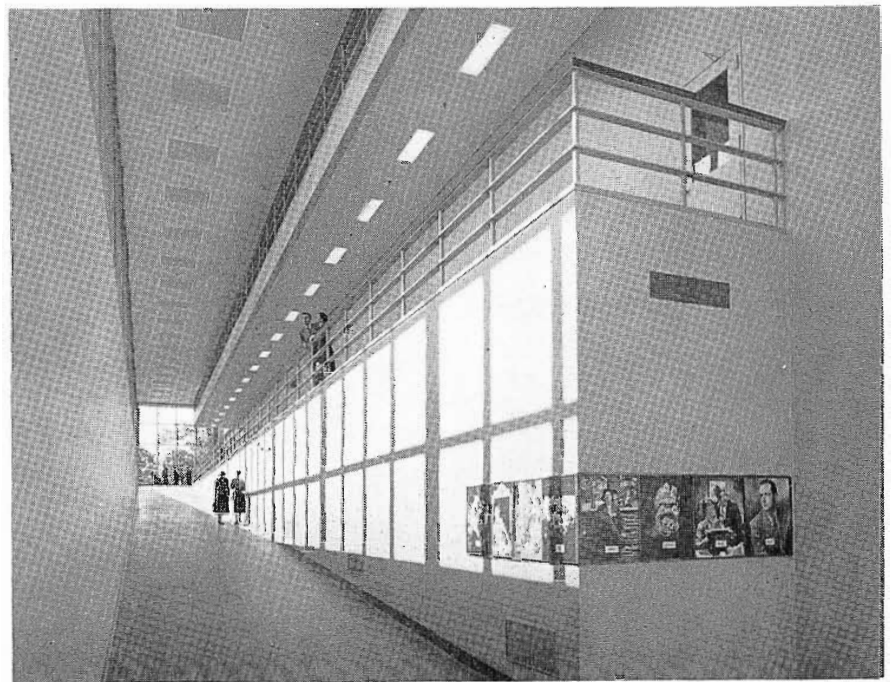
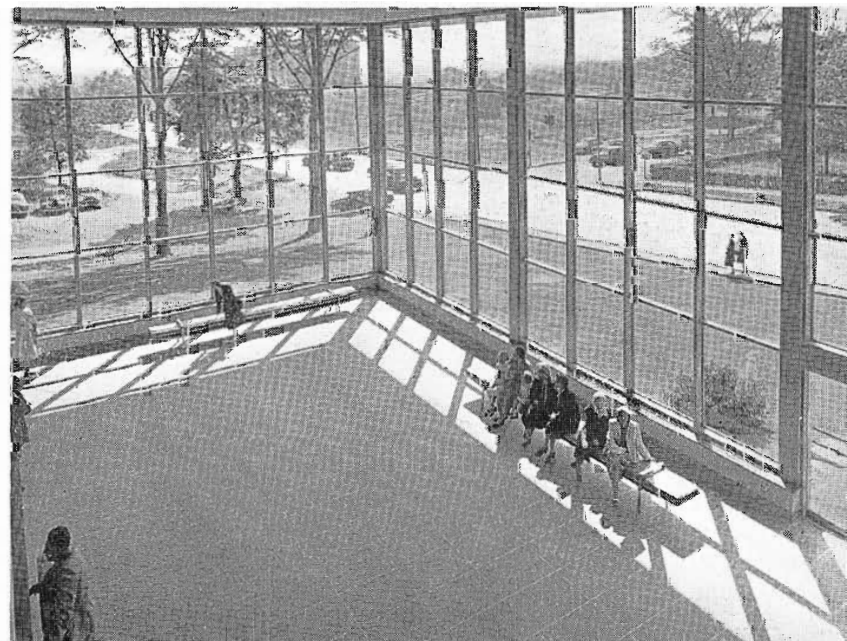
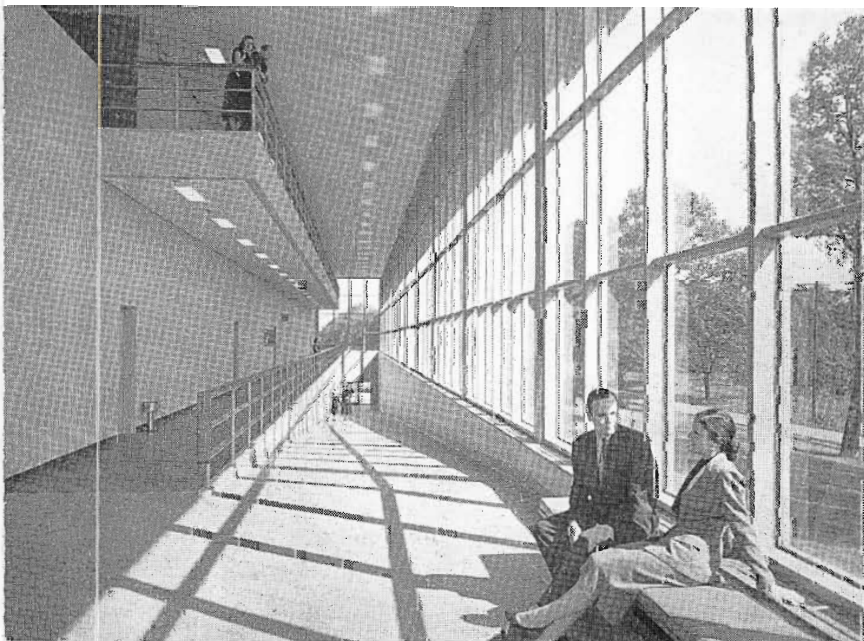

FIG. 9 (below). View of the ramp from the main lobby. Balcony at top left leads to executive and business offices on the second floor.

FIG. 10 (below, right). From this glass-enclosed corner of the main lobby a panoramic view of Schuylkill Valley is provided. This picture was made from the second floor lounge just above the reception desk.





**OPERATION  
GOLDFISH BOWL**

FIG. 11 (above). Both the AM and TV master control rooms have full length windows. Visitors in the lobby can watch the control room operations to their hearts' content. There is even a railing for them to lean on.



**SECOND FLOOR LOUNGE**

FIG. 12 (right). This lounge, on the second floor just above the entrance lobby, provides a convenient reception space for the administrative offices.

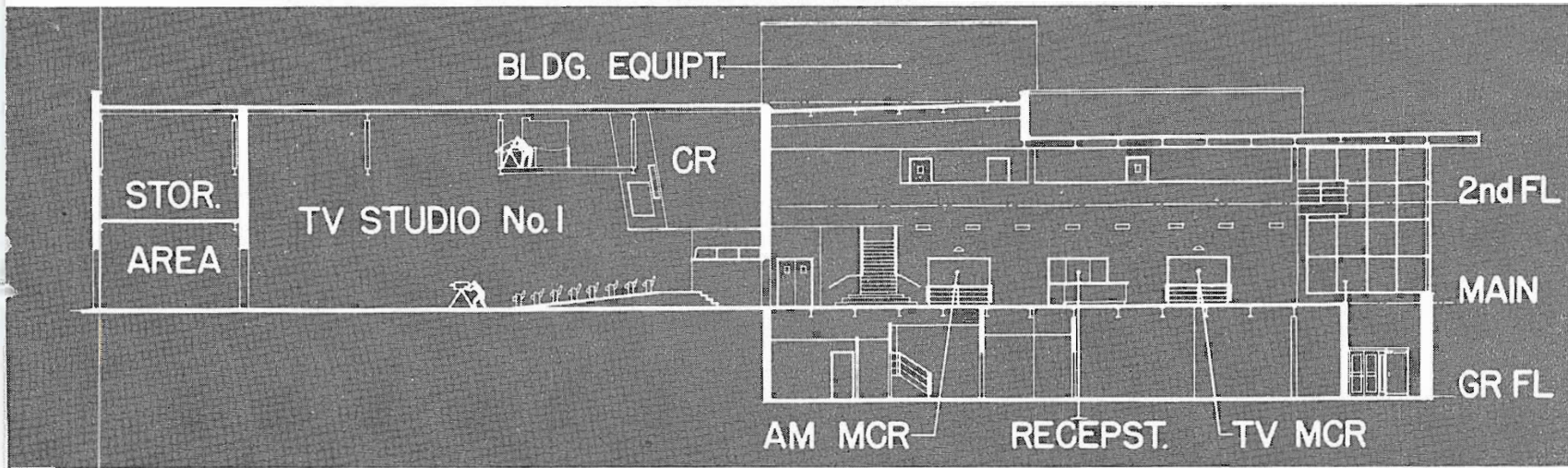

FIG. 13. Elevation plan of the WCAU building from the front. The left section of the building is of one-story construction, contains the four TV and three AM studios. The right section is three stories high with operating areas on the main floor, administrative offices on the second floor, and service facilities in the basement (which is at ground level in the rear).

## GENERAL PLAN OF THE WCAU STUDIO BUILDING

The building has been divided into two parts—one containing services on the ground floor, operational offices on the main floor and administrative offices on the second floor and the other housing AM and TV Studios and Control Rooms. This division is very satisfactory from an operational standpoint and has considerable advantage for soundproofing in that there are essentially no noise generating activities above or below the studios.

Having all operations, both radio and TV, on the main floor is an important factor in functional planning. It permits easy access for moving equipment and personnel among the rooms of each activity and between the two groups with little lost motion or time. It eliminates the use of elevators or stairways. The only exceptions to the common floor plan are the four TV control rooms and it was considered desirable that they operate on the upper level.

Departments are located for maximum efficiency in respect to the need for adjacency. Those departments which are used jointly by TV and AM, such as news and transcriptions are placed so as to be readily available to both.

Considerable thought was given to circulation and the result is shown on the main floor plan. Loss of time by operating personnel due to awkward corridor layout, can be expensive, over a period of years. We believe we have provided as quick and ready access among the operating rooms as was possible with the final plan.

Normal traffic flow on the ground floor is shown in Fig. 14. It will be noted that three main objectives are accomplished by this arrangement of facilities. First, the normal, or most often traveled, paths between areas are as short as they could possibly be made. Second, the three important types of traffic, i.e., properties, staff and public have entirely separate corridors so that they never meet or cross. Third, props can be brought from the outside into the TV studios in easiest possible manner, and without in any way interfering with station operation. This separation of traffic, while maintaining short interior communication paths, is in line with the most modern concepts of design efficiency. It is believed that this is the first large studio building in which this idea has been carried out in full.

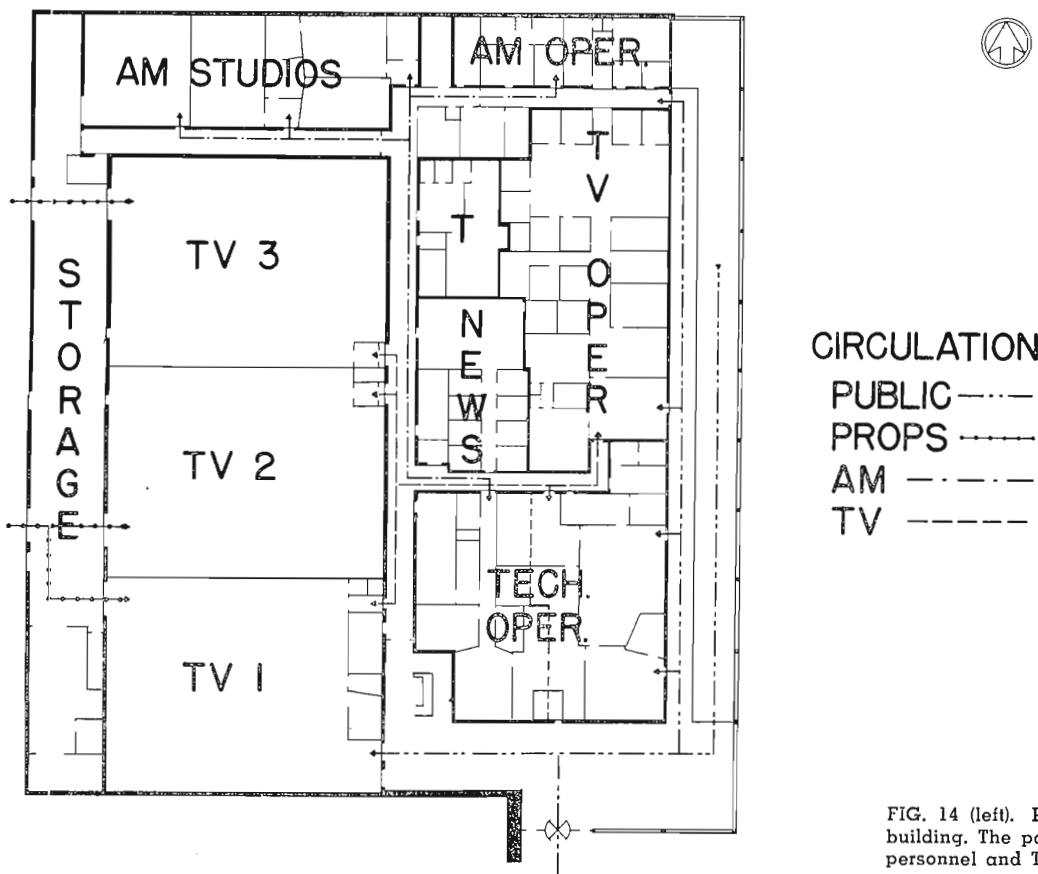

FIG. 14 (left). Plan showing "traffic" flow on the main floor of the building. The paths normally followed by visitors, property men, AM personnel and TV personnel are shown by broken lines with arrows.

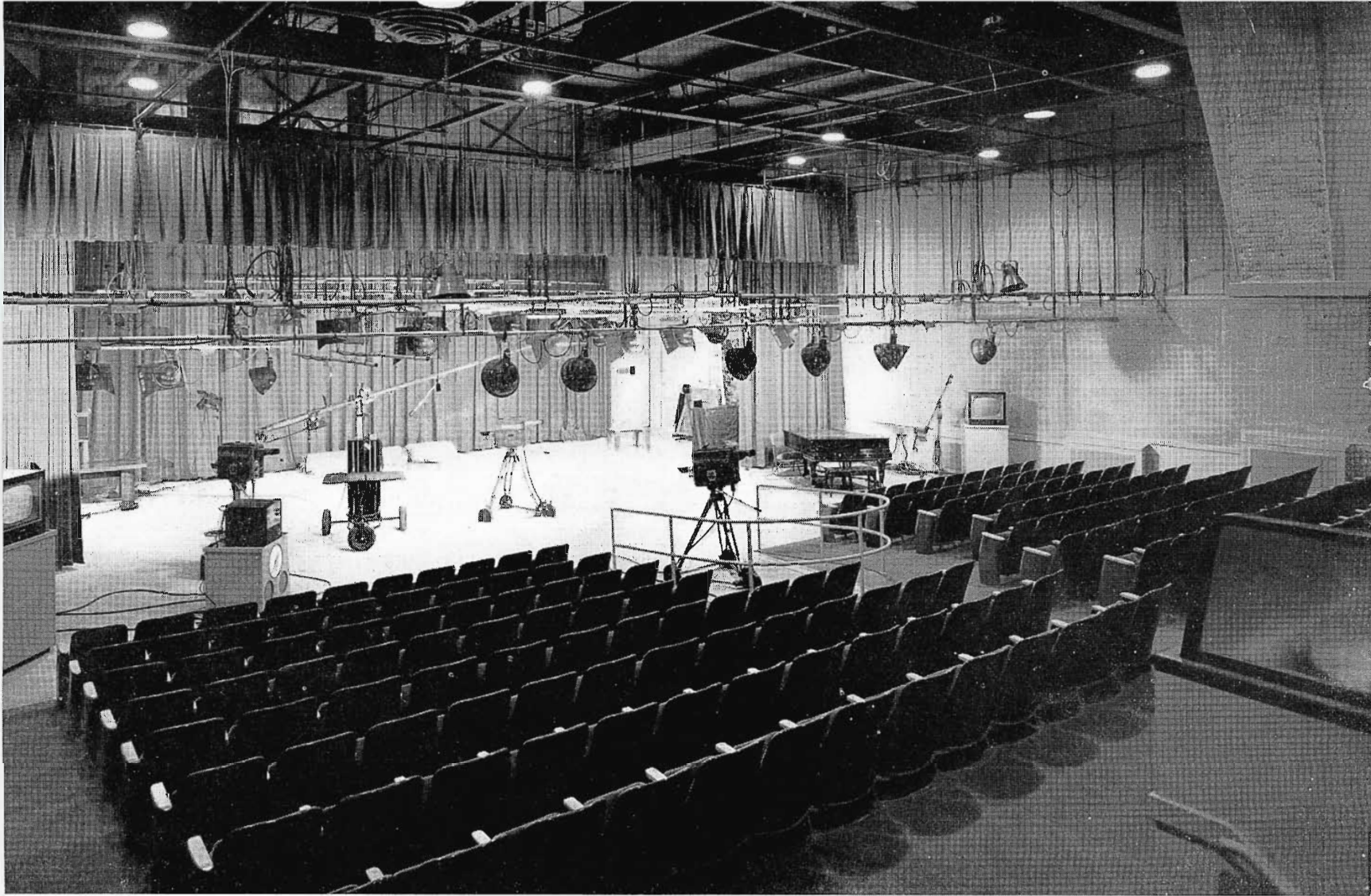

FIG. 15 (above). View of Studio 1 from the rear. Theatre-type chairs for 230 people occupy about half the total space in this studio, leaving an area 60 feet wide and 40 feet deep for staging. Several different draw and drop type curtains are provided so that various stage effects can be used.

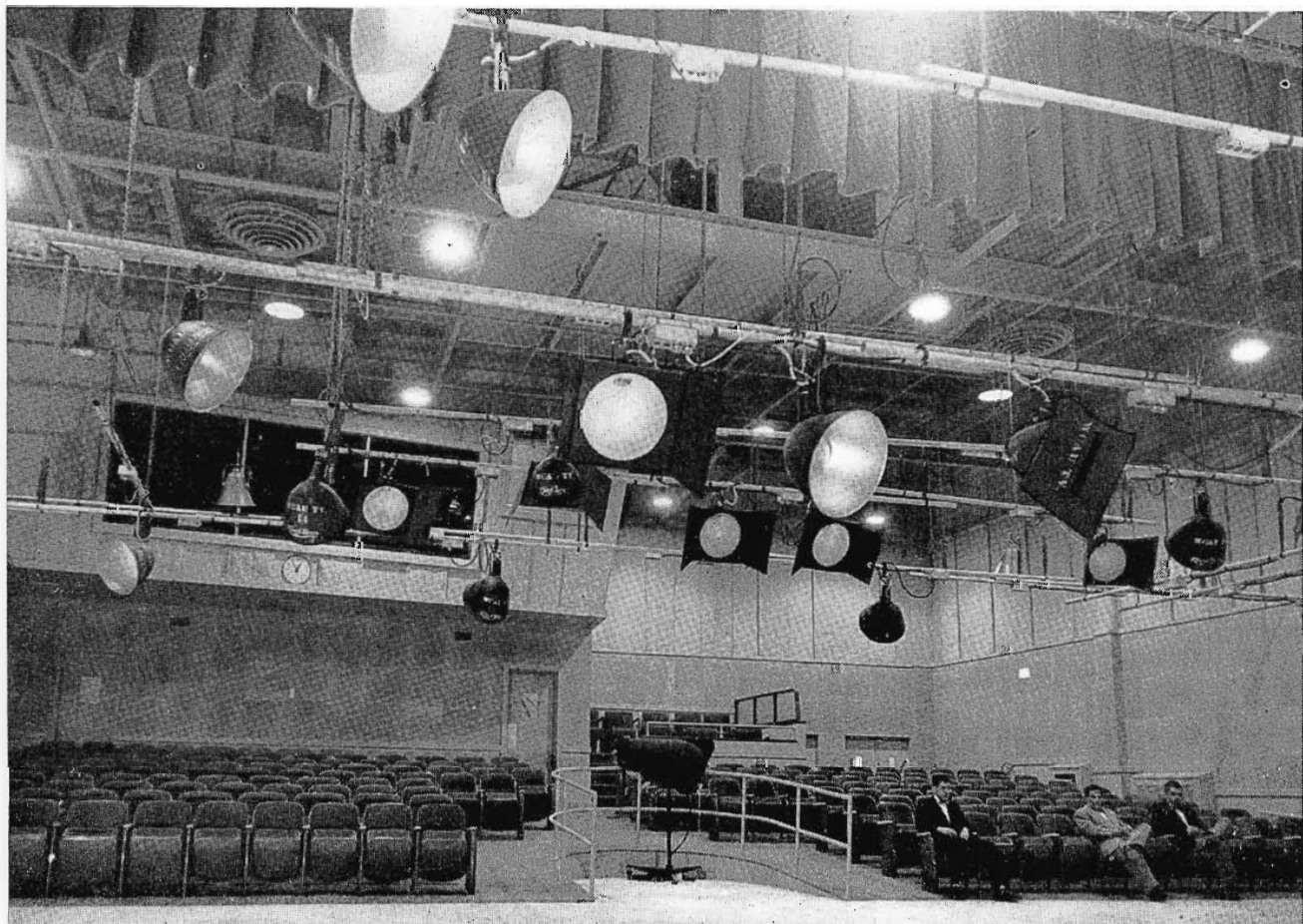

FIG. 16 (left). The same studio looking toward the rear. The control booth and announcer's booth overhang the ramped audience section at the left rear. At the rear center, and slightly elevated, is an open "clients' booth" which is one of the most unusual features of this studio. In the center foreground is a "camera well" which happened to be occupied by a large spotlight at the time this picture was made.

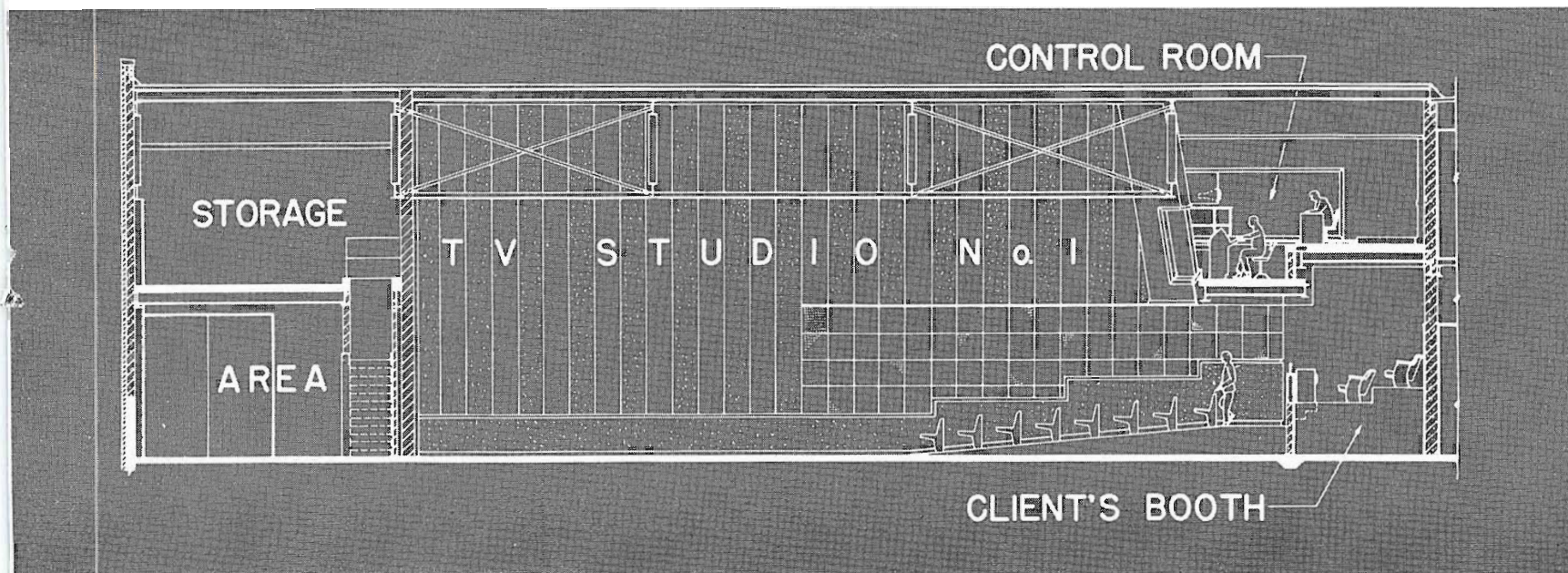

FIG. 17. Elevation plan of WCAU's TV Studio No. 1. The elevation of the audience section, the open clients' booth, and the two-level control room are shown in this drawing. The position of the TV receivers in the clients' booth and in the control room, above the window, are also indicated.

## WCAU'S AUDITORIUM STUDIO (TV STUDIO No. 1)

TV Studio #1 has a working area of 40 x 60 feet, seating for 230 persons, with clients' room and overhead control in rear. The entrance is from the main lobby and large doors in the east wall permit driving cars and trucks in to the working space.

Although the auditorium studio (TV Studio #1) has many interesting features for audiences, whose comfort and visibility have been fully provided for, it

was designed from a functional rather than a decorative standpoint. The overall layout, the placement of equipment, even the wiring have been so arranged to bring about optimum conditions for television production. One of the most important parts of any television studio is the control booth, and the booth in the WCAU Center's auditorium studio is one of the most modern and carefully designed in the country. The large cantilevered control

room, above the ramped audience section, contains a number of unique features, including: slanted glare-and-reflection resistant windows overlooking the sets, standard RCA 17 inch home-type receivers for monitors at the director's eye-level, complete remote control of all set lighting, an announce booth which can be used for extra lighting or as a camera platform, and a window into the adjacent studio for control of extra sets.

FIG. 18. Looking from the control booth into Studio No. 1. Floor length windows the full width of the control room provide unusual visibility of all parts of the studio floor. Only the audio operator sits on the lower level. The program director, video operator, technical director and lighting operator sit on the upper level where they have an unencumbered view of the whole studio. The receivers mounted above the window are at approximately their eye-level and at about the distance normal for home viewing.

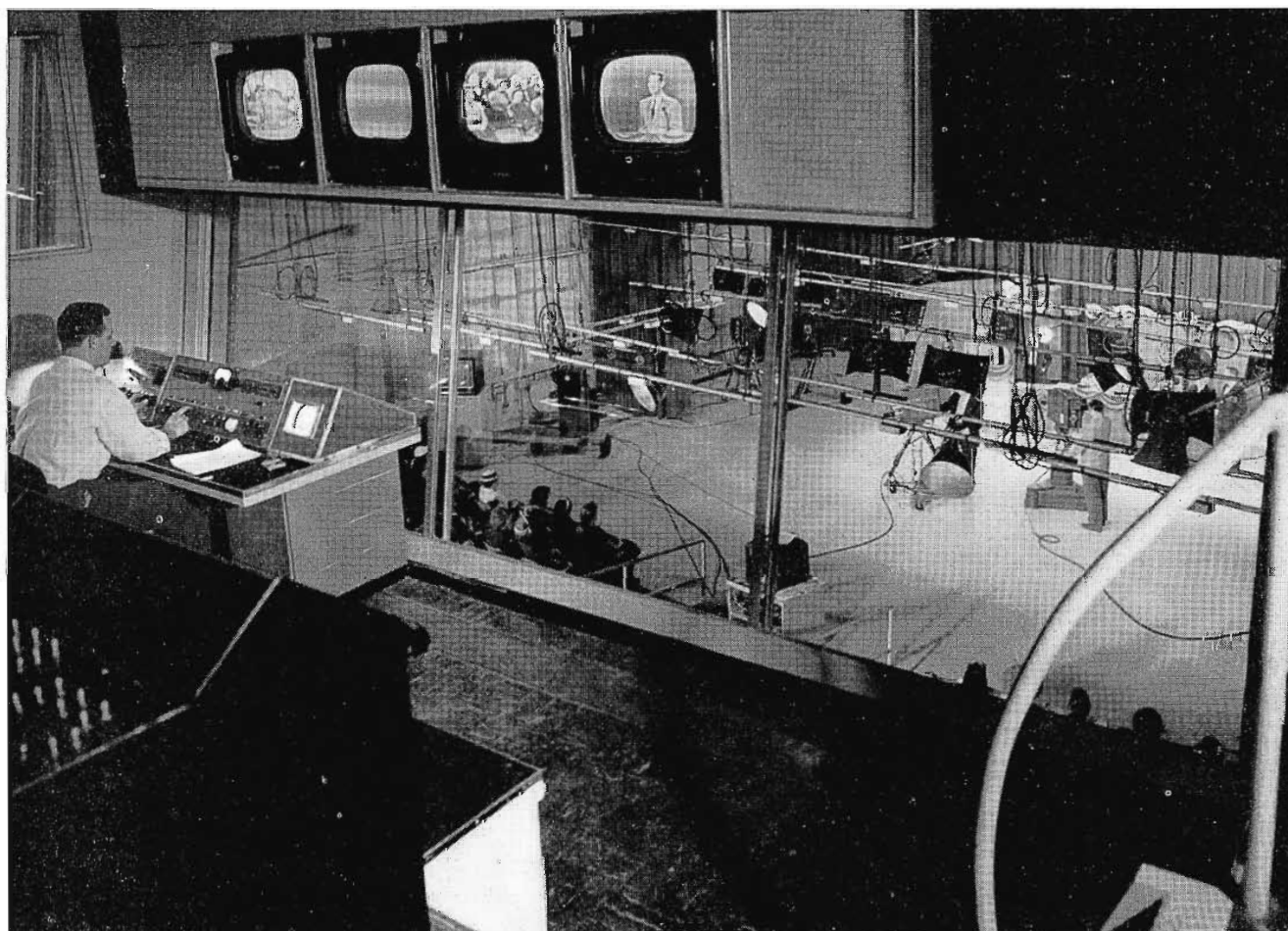

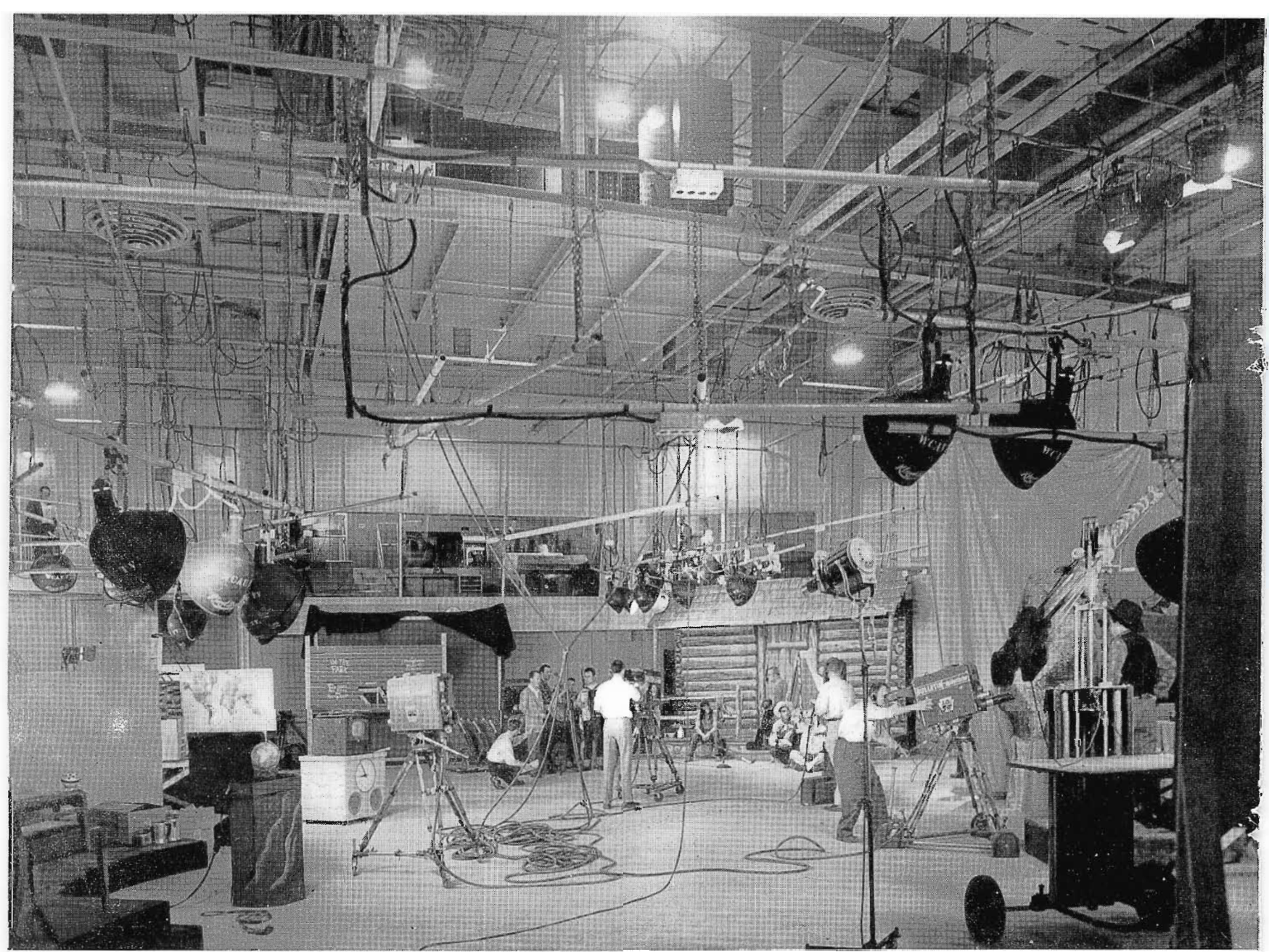
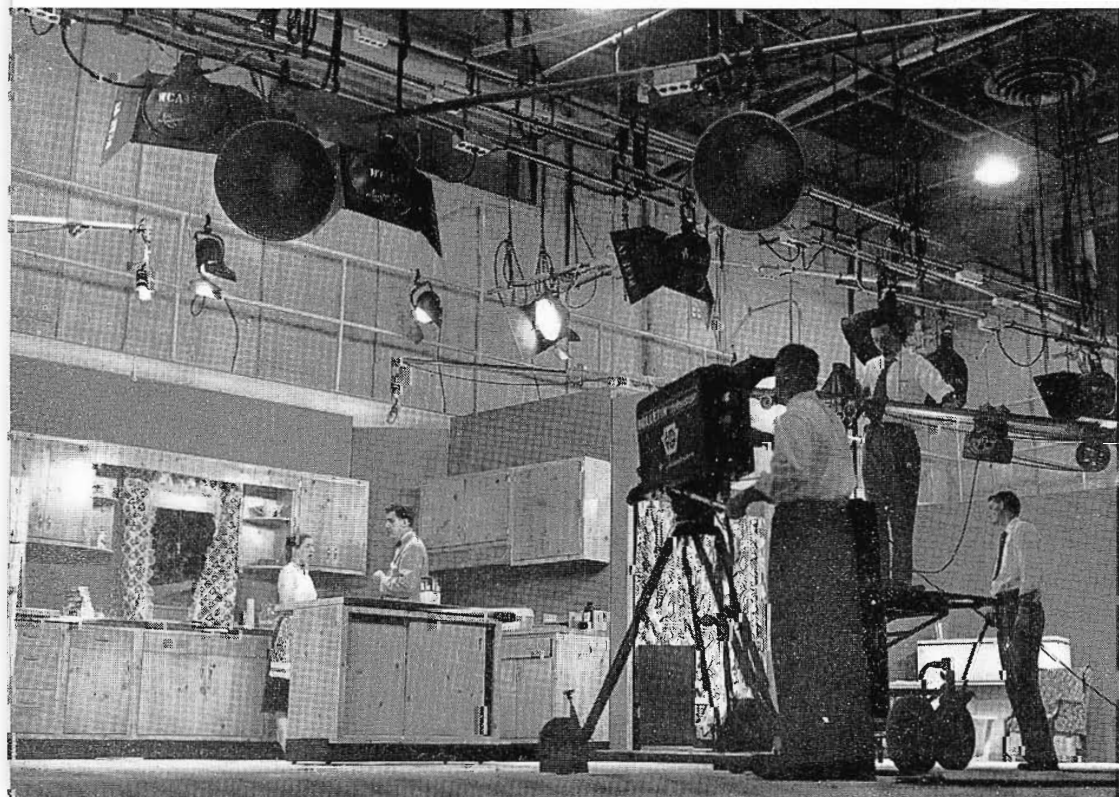

FIG. 19 (above). View of Studio No. 2 from the far end. The large windows of the elevated control room are at left center. The two windows at right center are those in the clients' room. Note the catwalk which extends from the control booth all the way around the studio. This can also be reached by steps from the floor.

FIG. 20 (below). A kitchen set in Studio No. 2. The availability of several large studios allows sets of this type, which are used for daily shows, to be left in place as long as needed.



## TV STUDIO No. 2

All three of WCAU's television studios have similarly equipped control rooms, the same twenty-foot clear height, overhead lighting and camera platforms, and acoustically treated walls. Since studios Number Two and Three have no audience section, each has 4800 square feet of set space, which will accommodate six 24-foot sets simultaneously, four more than the largest studio at previous location had room for. These studios also feature catwalks, accessible from the floor or control room, set at the proper height for securing the tops of sets and for back lighting to be mounted on the railings.

Studio No. 2 is normally used for the smaller sets required on day-to-day shows. Some of these sets, such as the kitchen set, are left in place more or less permanently. Others are put in place during the time programming is being carried from other studios.

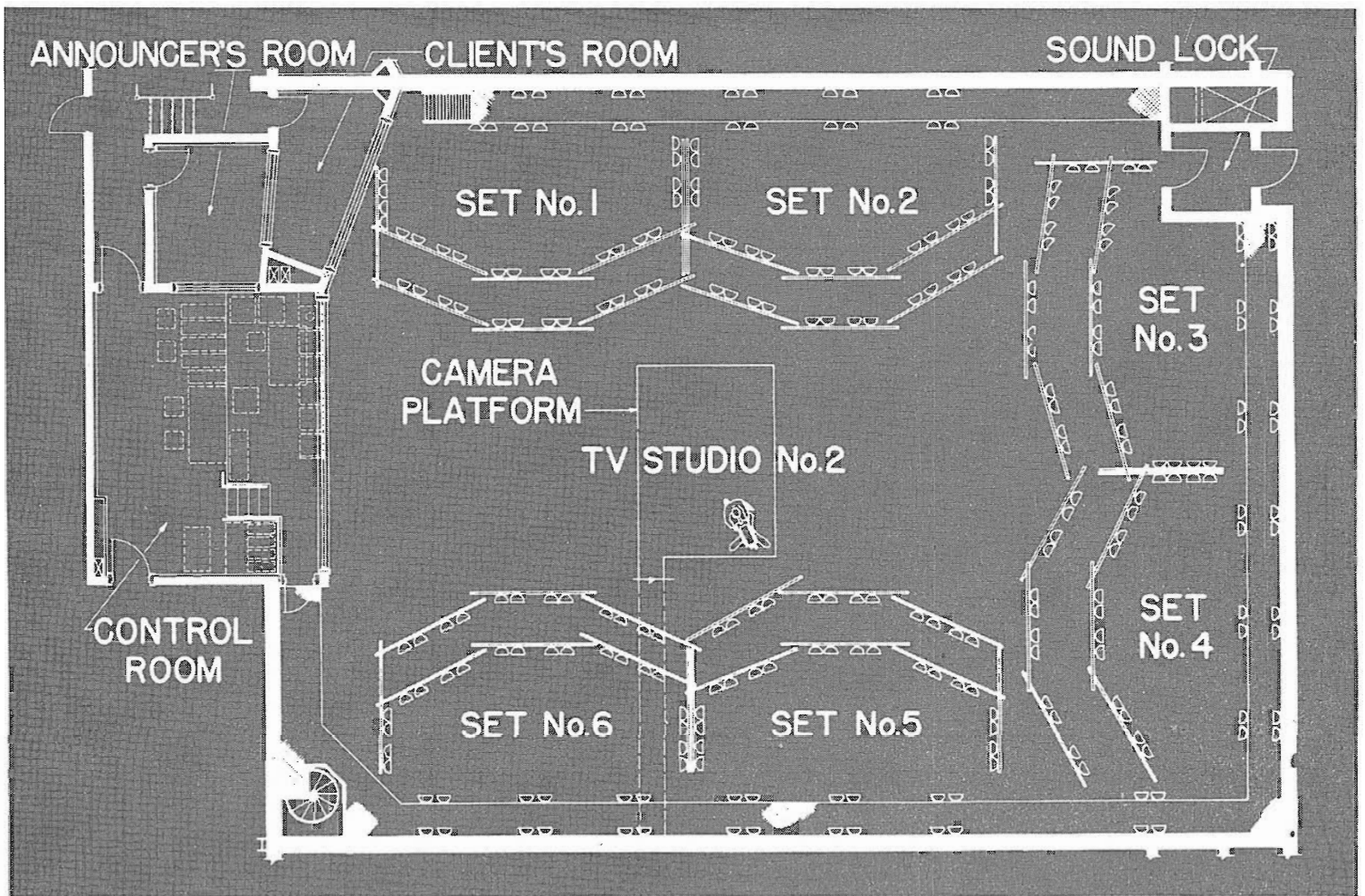

FIG. 21 (above). The large floor area of Studio No. 2 accommodates six 24-foot sets. In most cases all of the sets required for even an elaborate show can be set up beforehand, so that cameras simply move from one to another as action progresses. Because the cameras are in the center area they never have to be moved very far.



FIG. 22 (right). View of action on one of the sets in Studio No. 2. A big advantage of this studio arrangement is that lighting for each set can be arranged beforehand so that a very minimum of extraneous movement occurs during the show.

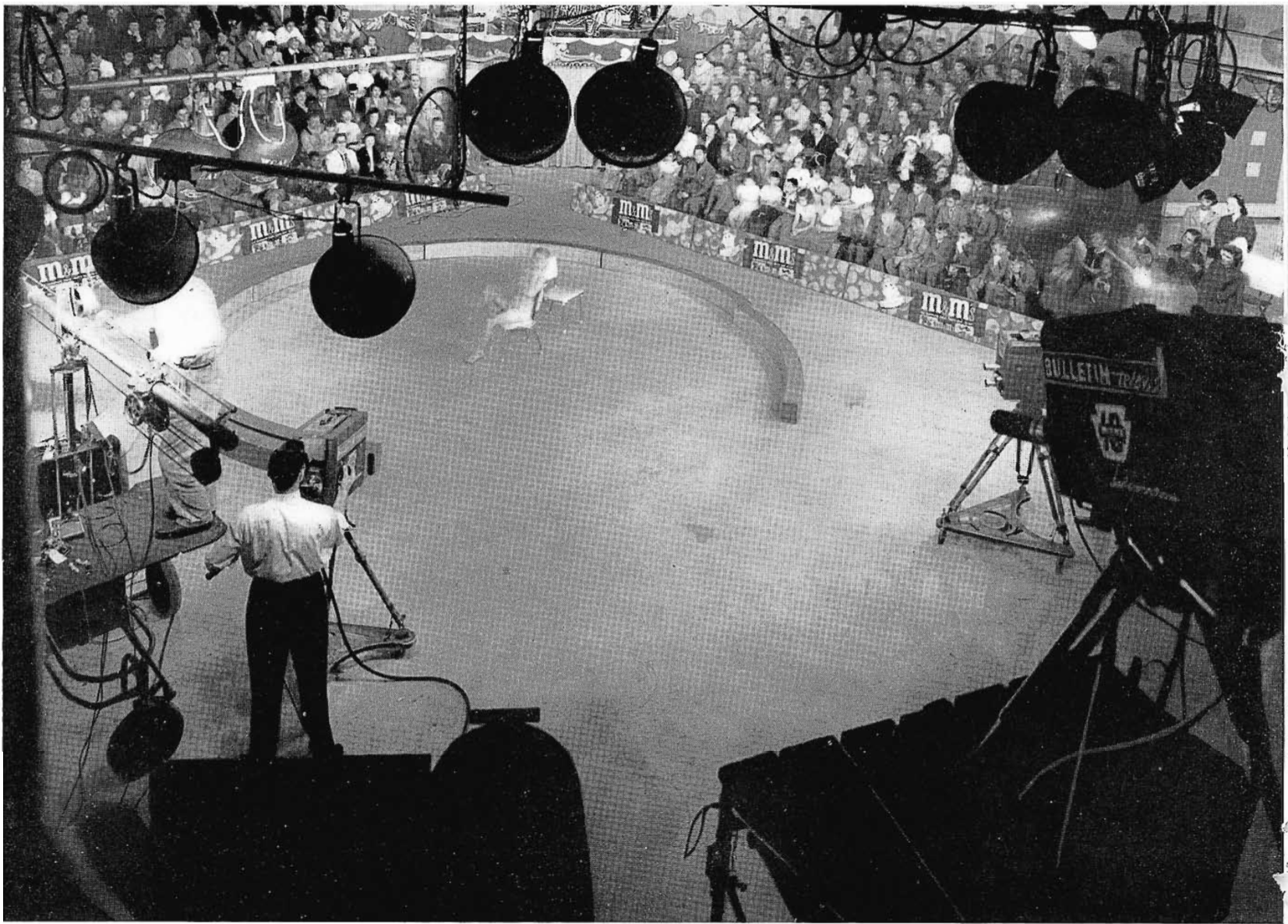

FIG. 23. View of Studio No. 3 as setup for "Candy Carnival", one of six shows fed to the CBS network by WCAU. Folding bleacher-type seats accommodate an audience of 400 and still leave room for a standard circus ring. In this show the audience actually forms a background for most of the acts. Note the band in the balcony at top center.

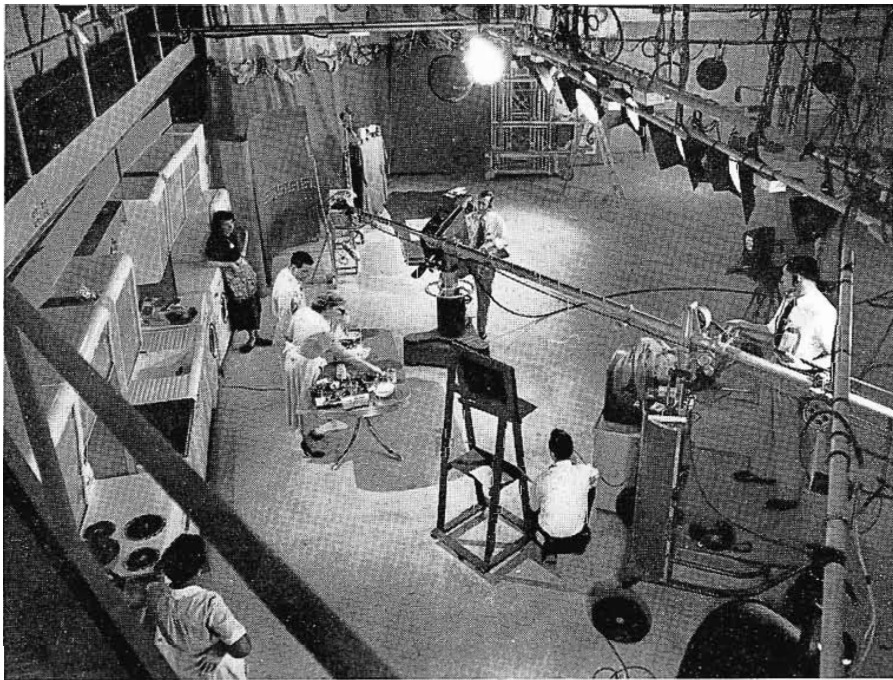

FIG. 24. When not in use for larger shows (as in Fig. 23), Studio No. 3 is used for medium-size sets as shown here. By keeping the heavier parts of such sets against the studio wall they may be left in place from day to day. Lighter backgrounds, placed in front, serve to hide them when the studio is used for other purposes.

## TV STUDIO No. 3

WCAU's Studio No. 3 is identical in size, arrangement, and equipment to Studio No. 2. This simplifies planning and scheduling, and adds considerable flexibility to studio usage. It means that standard sized sets can be constructed and used in either studio. Thus a show which normally goes on in Studio No. 2 can (if No. 2 happens to be tied up) just as easily be aired from No. 3. Similarly a show can be rehearsed in one studio and, if desirable, aired from the other studio. Props, lights and other equipments can be interchanged at will.

For normal day-to-day operation WCAU has a number of smaller sets more or less permanently in place in Studio No. 2 (as shown on preceding page) but keeps the main floor area of Studio No. 3 relatively free of heavy sets so that it will be available for telecasting or rehearsal of larger shows such as the "Candy Carnival". Folding bleachers, which can be set up wherever is most convenient, are used to provide audience seating on shows where an audience is desirable.



## CLIENT and GUEST FACILITIES

Many improvements in client facilities have been incorporated in the Center. Each of the three large television studios has a client booth, and there are two comfortably furnished, acoustically treated conference-audition rooms, one adjacent to the television and radio sales department and the other next to the radio programming department. A third conference-audition room, for television production personnel, is located in the TV production department. The audition rooms have adjoining booths with film and sound projection equipment. WCAU-TV's services to its clients and their agencies will be supplemented with a completely equipped commercial film department.

WCAU has also provided generously for the comfort of its guest performers. Spacious, well-lighted dressing rooms are provided convenient to the studios. They are located on the ground floor in an area of the building which may be entered directly from the parking lot. Thus performers need not mingle with the public when entering or leaving the building.

FIG. 25 (right, above). Studios 2 and 3 have enclosed clients' booths like that shown here. At the same elevation as the control room, and adjacent to it, they have a full view of the whole studio.

FIG. 26 (right). There are three "conference-audition" rooms such as this in the WCAU building. They are located next to television and radio sales, radio programming and television production. Each has an associated film projection booth so that programs may be reviewed without the distraction of sound or projection equipment in the viewing room itself.

FIG. 27 (below). Generously sized dressing rooms for performers are located on the ground floor near stairways which provide quick access to the studio floor. This shows the ladies' make-up room.

FIG. 28 (below, right). Similar facilities are provided for men. A mirror extends the full length of one side of the rooms. Diffused lighting above and below the mirror provides a high-level of illumination similar to that of studio close-ups.

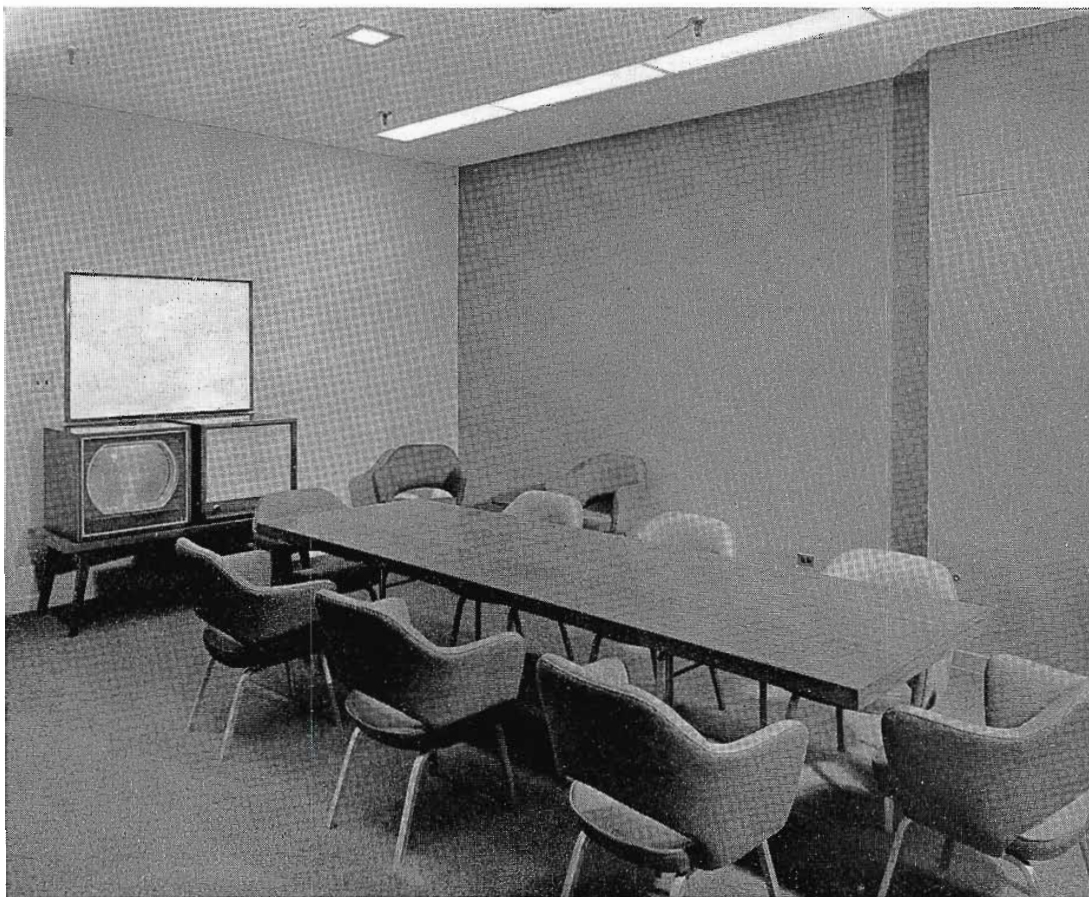
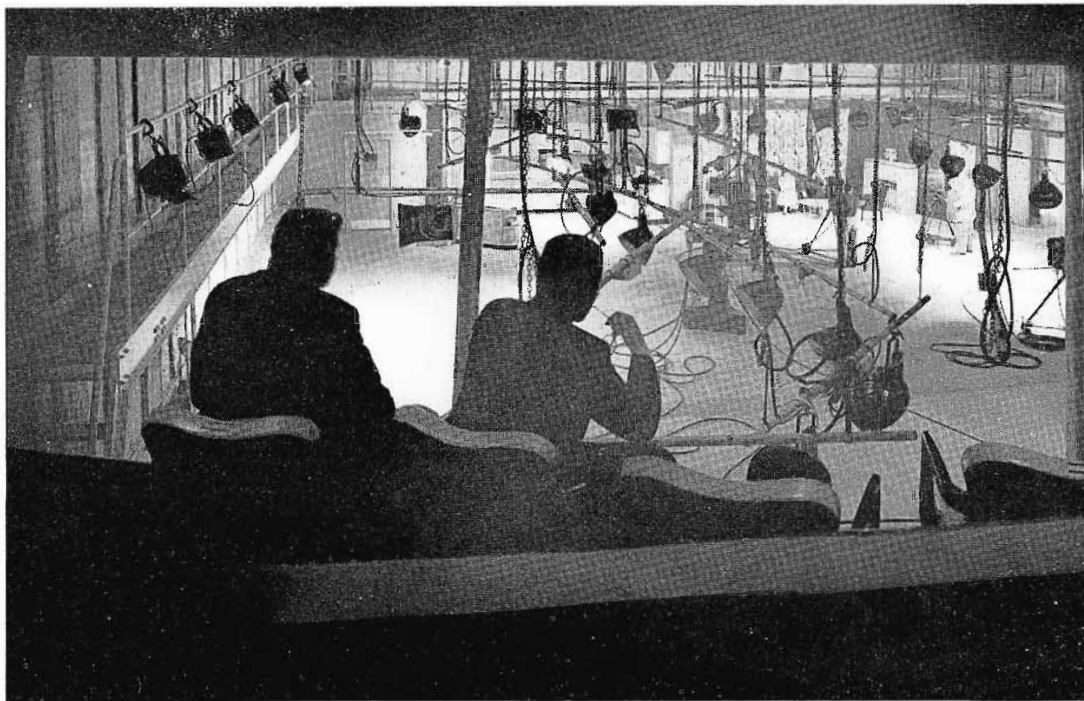

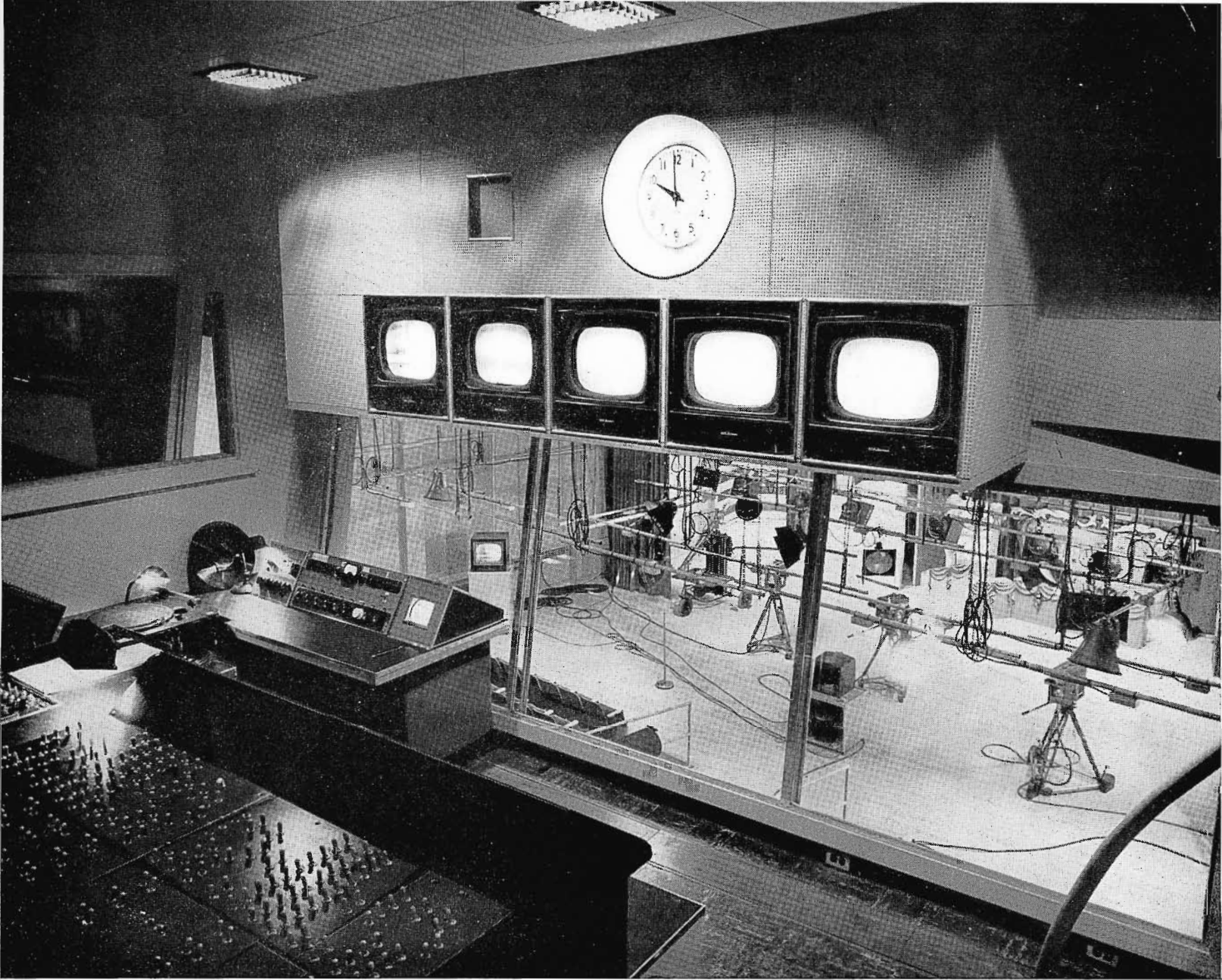
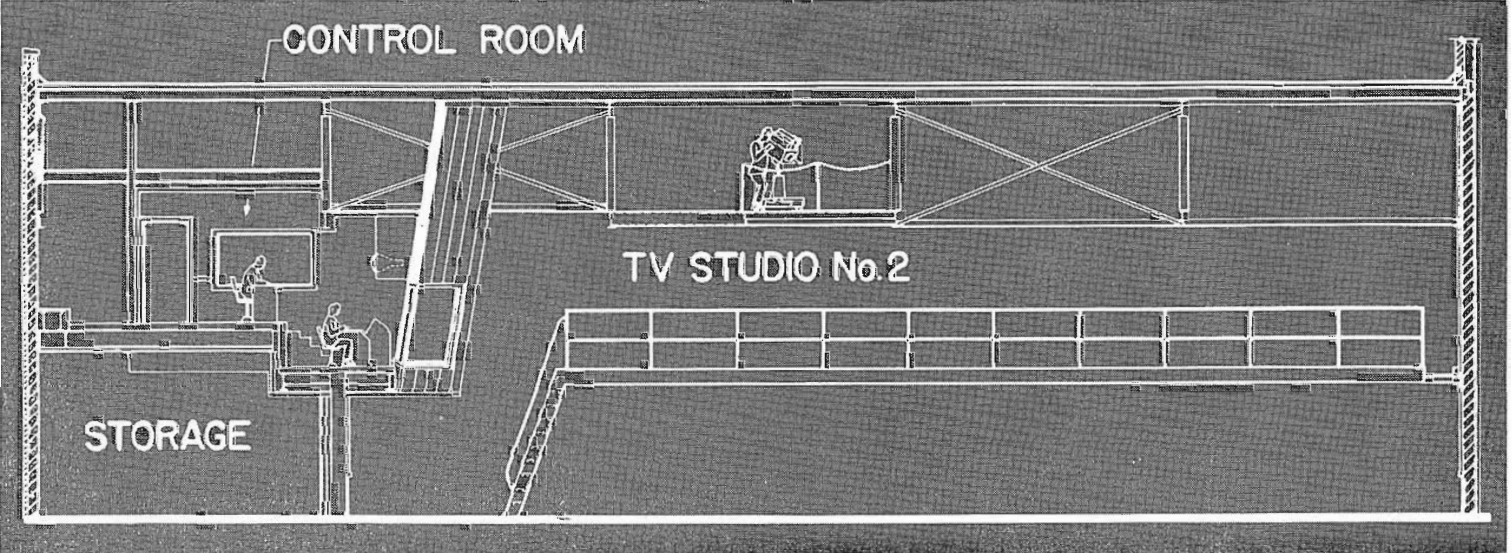

FIG. 29 (above). The control rooms of all three TV studios are practically identical. A 6-foot high Solex glass window the full width of the control room, plus the elevated position, gives unequalled visibility of the whole studio. Another unusual feature is the fact that only the audio operator is on the lower level. He sits at a console which consists of an RCA BC-2B Consolette, an RCA OP-7 Amplifier (for extra mic positions) and a program monitor mounted in a streamlined desk designed by the WCAU engineering staff. The video operator, program director and lighting operator sit on the upper level where they can observe the camera, preview, and program pictures on the 17-inch monitors mounted above the window.

FIG. 30 (below). This simplified elevation drawing shows the relative position of the two control room floor levels. The lower level (where the audio operator sits) is 10 feet above the studio floor. The upper level is 3 feet higher. Note that the audio operator sits in the far left corner of the booth, so that for the most part the operators on the upper level do not have to look over or around his head.



## WCAU TV STUDIO CONTROL BOOTHS

The TV studio control rooms are almost identical in layout and in provision for equipment. The floor is on two levels with audio man below and director and video man above. Good vision is provided to studios and to Announce booth adjoining each control room. An extra vision window has been set between Studio #1 Control and TV Studio #2 so that a single crew and control equipment may be used, with vision, for a program requiring two studios or one requiring a separate studio for commercials. Seventeen-inch RCA monitors are mounted over the observation window between the control room and the studio and are driven from the camera control units. They are in excellent line of vision for the director, and at the proper viewing distance. These monitors assist the director in establishing composition and picture relationships, using a monitor that is comparable in size to the picture tube in the average viewers home.

The angles of all vision windows have been adjusted for minimum light and sound reflections. In addition, the observation windows from the TV control rooms and the announce booths are glazed with Solex. This is tinted glass made by Pittsburgh Plate Glass Co. with a transmission loss of about 75%. This permits good viewing of the monitors by the Director and Control room men because it reduces the variation in light intensity between the brightly lighted studio and the face of the monitor tubes.



FIG. 31 (above, right). This view of the control room of Studio No. 2 shows the console positions on the upper level. The video operator is on the far side. (Just beyond him is the window of the announcer's booth.) The program director sits in the center. Nearest to the camera is the lighting operator. (The lighting system is described on the following page.) Note the wiring duct beneath the console.

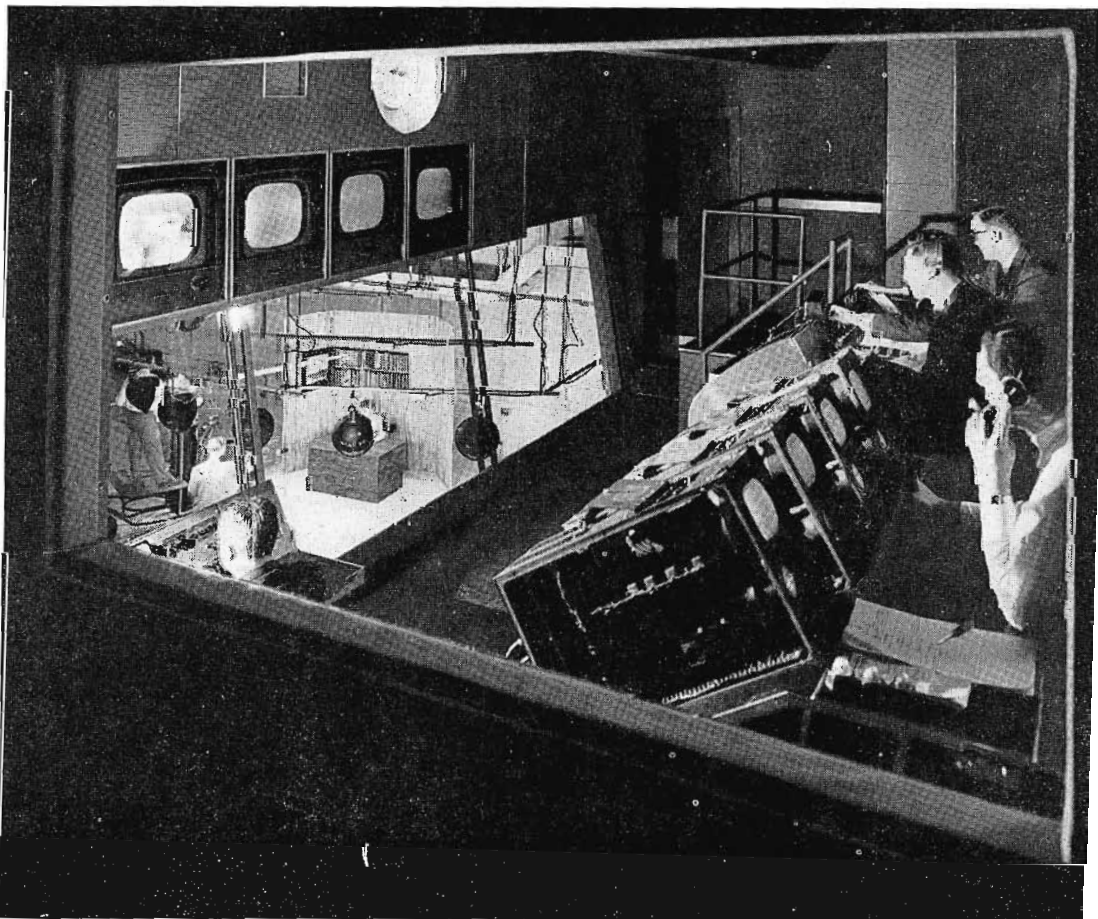

FIG. 32 (right). This is a view of the same control room from the announcer's booth. The video operator's position next to the window can be seen in this view. The video console consists of the camera monitors associated with four RCA TK-10A Cameras (on which WCAU has standardized) plus an RCA TM-5A Master Monitor. The door at the far end of the room leads to the catwalk which runs around the studio. On the upper level to the right of the door are three cabinet racks which contain power supplies, distribution amplifiers and other rack mounting units associated with the control room equipment.

## LIGHTING FACILITIES IN WCAU TV STUDIOS

Each studio has been divided into stages or sets for lighting purposes. The spots and floods are clamped to metal batons which are suspended by chains from a pipe grid, mounted from the under side of the lower chord of the Tele-Truss. Adjustment of the chains permits raising and lowering of the batons and the angle and proximity of one baton to another. The lights may, of course, be adjusted individually for angle. All lighting circuits are brought to a distribution center on a platform mounted in the truss area and accessible from the catwalks. A mercury relay is used for each circuit with control at an operating console in the studio control room. Equipment mounted on the platform includes relay, patching and power distribution panel boards. Incidentally, the platforms are intended to be used for cameras to permit "down-shots" into the studio and for spot lights.

Each mercury relay is connected to two lights and control for each relay is by a small switch on the light operating console. In addition, these circuits are mastered so that lighting changes can be pre-set and used by the Director during a show.

A saturable reactor type of dimming is used. Eight 3 kilowatt dimmers are mounted on the lighting platform with dimming controls on the operating console in the studio control room. The patching panel permits dimming control of any light circuit either on the same or among any of the six sets. These circuits are also mastered so that by pre-setting the switching and patching, all or a portion of the light on any set can be controlled by the Director.

FIG. 34 (left). All studio lights are controlled from this operating console in the control booth. Each of the switches on the horizontal part of the board controls a mercury relay (in the distribution box over the studio). Each relay controls two lights. The control circuits can be tied together to master switches so that any pre-set group of lights can be controlled by one switch. On the upper (sloping part) of the console are dimmer switches. These too can be mastered so that one control operates a given set of lights as desired. The whole system is completely flexible and, most important of all is located so that the director has complete control at all times. This system was planned and the installation supervised by George Lewis, Chief Engineer of WCAU stations.

FIG. 33 (above). All of the lighting in the WCAU studios is of the "off-the-floor" type. Cluttering up of the studio floor by dolly-mounted light units is avoided (in all but very rare instances) by providing a very large number of ceiling mounted units. Interestingly, these are all incandescents (a change from WCAU's old studios, where background lighting was fluorescent). The lights are clamped in groups on pipe batons. Each baton has an outlet box for four lights (spots or floods). The batons are hung by chains from the overhead trusses, so that this whole group of lights may be easily raised or lowered. The picture above is a view of lights in Studio No. 1. In Studios 2 and 3 the batons are arranged in groups corresponding to normal set usage. (See Fig. 21.)

## TELE-TRUSS CONSTRUCTION IN WCAU TV STUDIOS

Much of the flexibility of the WCAU studios is due to the use of Tele-Truss construction for support of the roof over the studio section of the building. The Tele-Truss was designed and is fabricated by the Austin Company of Cleveland, designers and builders of the WCAU Center. It is designed to support substantial weights either resting on the top of the lower chord or suspended from it. The absence of diagonal members permits air conditioning ducts, piping and catwalks to run the full length of the upper part of the studio and the installation of lighting and other equipment in the truss area. Between the trusses are platforms for the light distribution panels and for an overhead camera position.

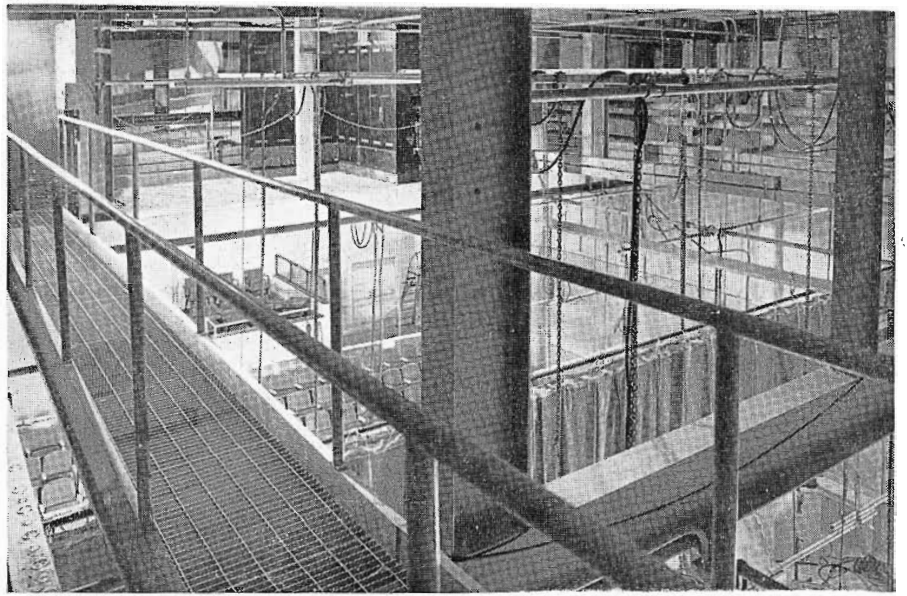

FIG. 35 (above, right). View of the Tele-Truss area over the center of Studio No. 1. Absence of diagonal members provides space for ducts, catwalks, platforms. Cabinets on platform at upper center contain light distribution controls.

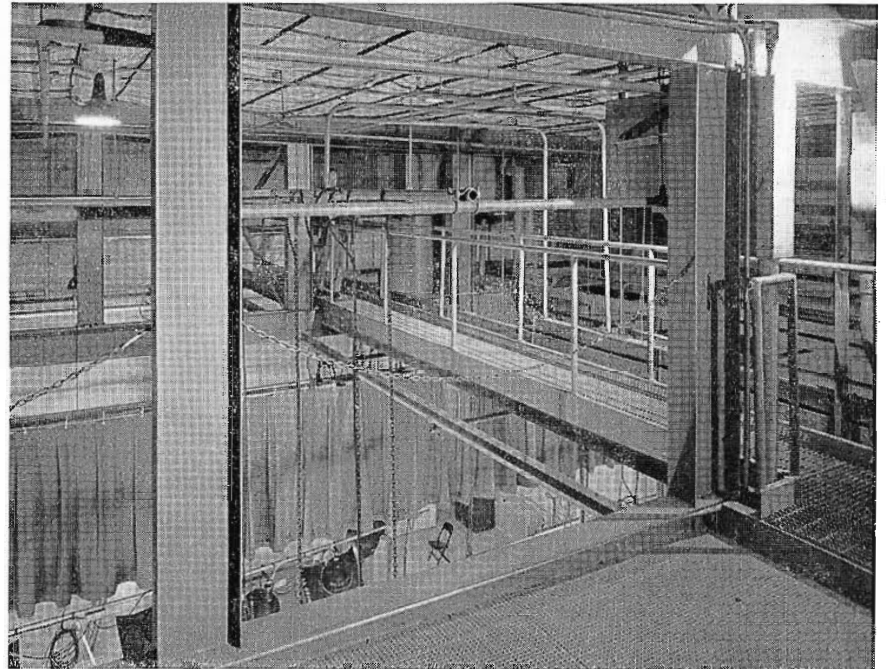

FIG. 36 (right). Another view of Tele-Truss area. This is from the platform provided for an overhead camera position. Note pipe framework from which light batons are suspended.

FIG. 37 (below). A simplified cross-section drawing which illustrates the advantages of Tele-Truss construction as a roof-support for large studios.

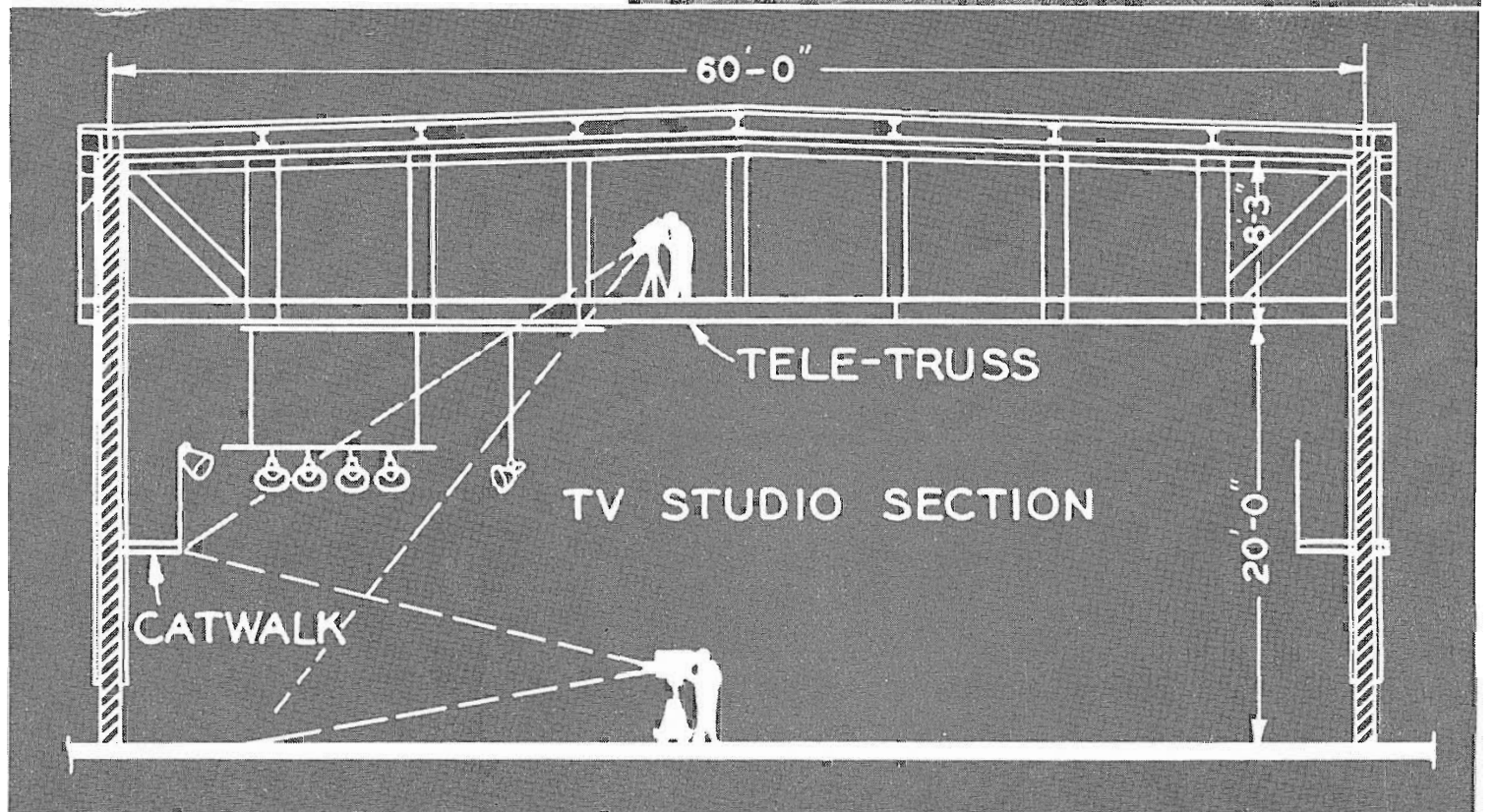



FIG. 38 (above). This is the WCAU TV Master Control Room as seen through the window from the main lobby. The film and announce camera monitoring positions are at the long console on the far side of the room. The master control switching console, especially built by RCA to WCAU's specifications is at the extreme right. The door at the left rear leads to the projection room, part of which can be seen through the window at the right of the door. The window further right looks into the announce booth, and through a second window into the part of the projection room where the announce cameras are located. The floor arrangement of this section of building is shown in Fig. 46.



FIG. 39 (left). A closer view of the camera control console. This console includes two live camera monitors (for the RCA TK-10A Cameras in the projection room), three film camera monitors (for the three RCA TK-20A Film Cameras in the projection room), two audio mixer panels and a film switching control panel. Camera shading, switching of film cameras, etc., is performed at this position. Note that 17-inch receivers, connected as line monitors, are mounted above each control position. The intent (as in the control booths) is to provide monitoring of the picture "as it is seen in the home".

## WCAU's TELEVISION MASTER CONTROL ROOM

The TV Master Control Room includes a custom-built relay switching system built by RCA to WCAU's specifications. Twelve video and seven audio input circuits provide for studios, film chains, network and remotes. Three output circuits feed the main transmitter, network and an audition or preview channel from any of the inputs. Monitor switching controls the connecting of video monitors among the three outgoing channels. There are provisions for pre-setting as many as three inputs in advance. The audition channel can be used as a preview circuit for the transmitter and network outputs. A memory circuit is incorporated to operate flashing lights contained within the pushbuttons. This notifies the operator that a new "pre-set" has not yet been made on a specific row of buttons. The operator then clears the "flash" warning by pre-setting any desired input. Relay switching is used for audio circuits also with essentially the same system used for video. Both video and audio relays can be tied together for simultaneous switching, if desired, or they can be separated for individual control. Of the twelve video inputs, six would correspond to identical audio inputs such as network, remote, Studio #1, etc. Six video inputs from the projection room would have their corresponding audio mixed by an audio console in master control. A dissolve super-imposition circuit, with a mixing amplifier is available, using any two of the input circuits. It is used to good advantage for film inserts with live program, live inserts with film program, multiple points of origination and for commercial spots, on a fade or super-imposition basis. Audio and video "lever" type faders on this circuit are independent of each other but are physically arranged so that both levers may be grasped in one hand to operate in unison. A second switching console is planned with duplicate facilities, which may be required for future expansion. Space is allowed for it and rack space is provided for the relays and associated equipment.

FIG. 40 (right, above). Closeup of the film and announce control console showing operator adjusting audio level on one of the two audio mixer panels (the other can be seen just over his shoulder). These audio panels were designed and built by WCAU engineering staff. Other components of this panel are standard RCA video units.

FIG. 41 (right). Closeup of the master switching console which was custom built by RCA to WCAU's specifications. Seven audio and twelve video input circuits are brought to this console. By means of pushbuttons which control switching relays, the operator can connect any of these to any of three outgoing circuits.

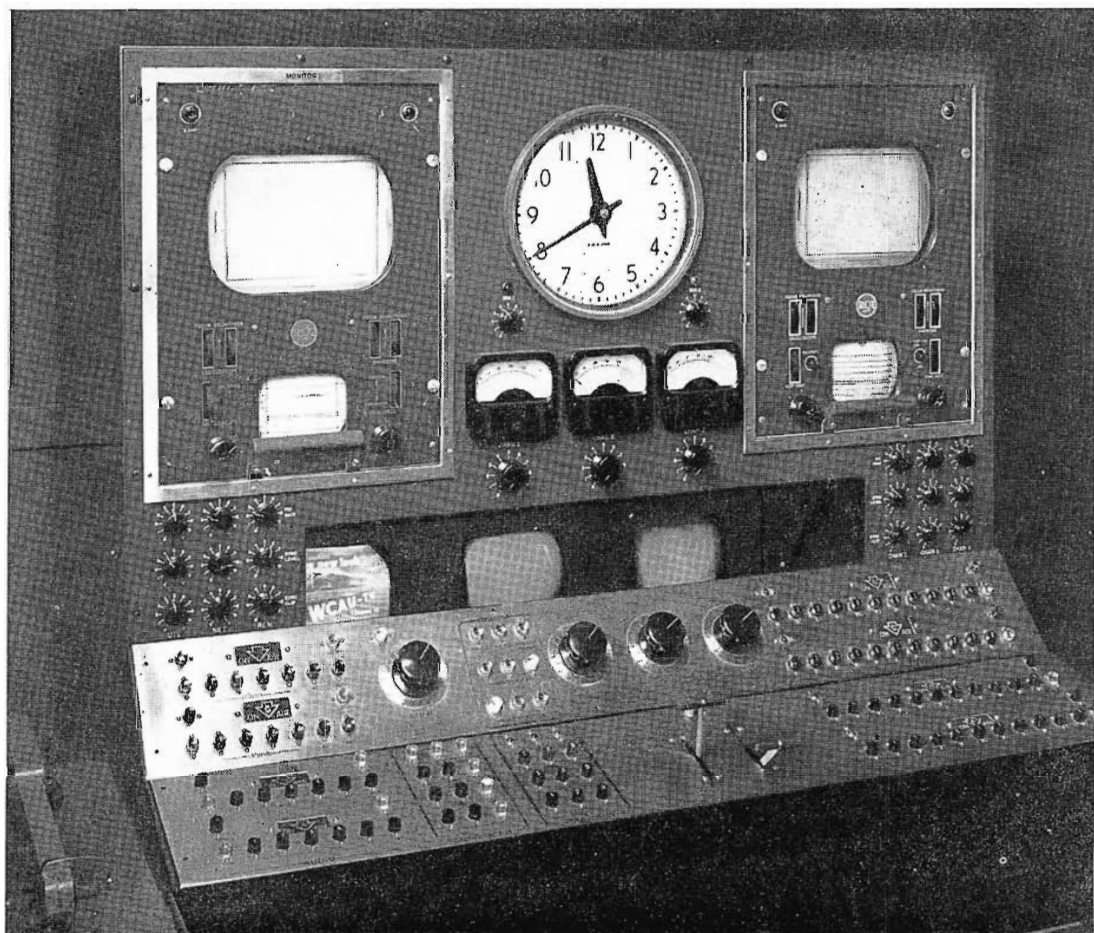

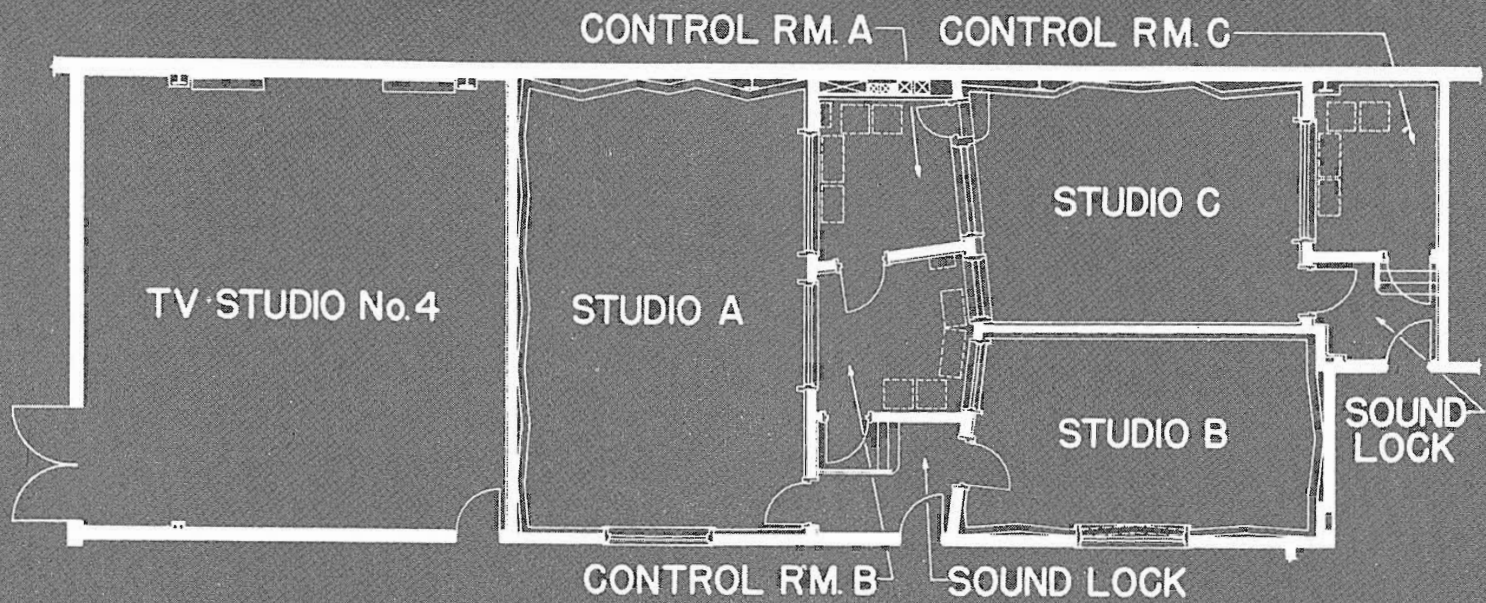

FIG. 42. Floor plan of the main radio studio area. Location of this area in the overall building plan is shown in Fig. 4 and Fig. 14. Each studio has its own control booth (all TV Studios are equipped so that they may be used for radio programming whenever a larger studio is required).

## WCAU AM STUDIOS

There are four AM studios and, in addition, all TV studios are wired for radio broadcasting. Each of the AM studios has its own control room. However, Control B has been placed so that there is vision into Studios A, B and C. This will allow control of all three from one set of equipment and with one technician if nature of program permits. Studio #4 is set up for both TV and AM operations and adjoins both the TV and AM studios. Regular use of this studio by TV and its availability for occasional use by AM, when a larger studio is required, eliminates a fairly large area being on a non-productive basis for much of the time which as you know, happens when a large studio is used exclusively for occasional AM requirements. All AM control rooms are equipped with RCA consolettes, two turntables and standard monitoring and talk-back facilities.

Standard form of isolation and rock wool are used for insulation and acoustic treatment. Serrated walls and ceilings prevent parallel surfaces of any substantial size. Low velocity air movement is part of air conditioning design to reduce noise from this source.

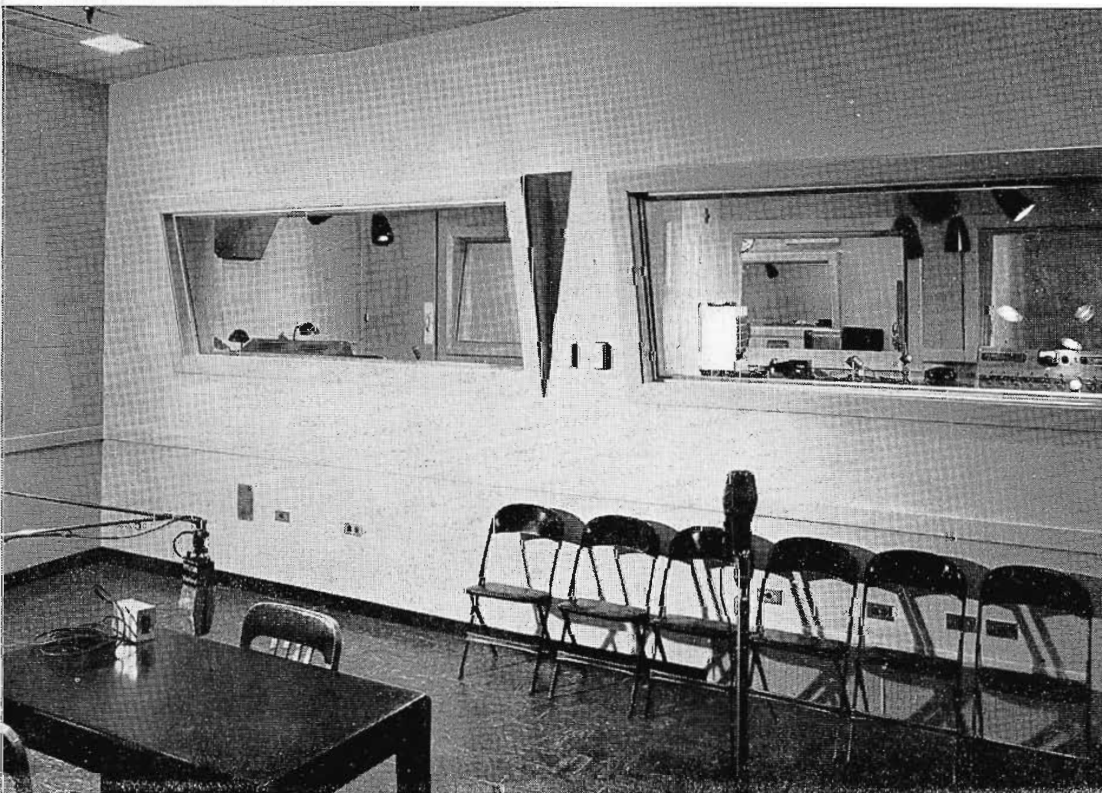

FIG. 43. View from Studio A looking into Control Room A (at left) and Control Room B (at right). Note that one can look through Control Room B into Studios B and C, and through the latter into Control Room C. In addition to these three studios there is a fourth regular studio, D, and a small announcer's studio. The two latter are adjacent to the radio master control room in the operational block (see Fig. 46).





FIG. 44. Radio master control room at WCAU. Console is a deluxe RCA unit custom built for WCAU. Racks of RCA amplifiers and other units at the right form the wall between the control room and the equipment room which is located between the radio and TV master control rooms (see Fig. 46).

## WCAU AM MASTER CONTROL ROOM

The AM Master Control Room is located adjacent to the lobby, so that its operation, like that of TV Master, is in full view of the public. The master control console is a deluxe type RCA unit custom built for WCAU. It provides for ten input circuits and six output circuits with standard monitoring and auxiliary circuits. Relay switching is used and provision is made for "pre-set" operation. In addition to operating as master control, this console supervises facilities of Studio D, the announcer's booth, which adjoins it (see Fig. 46) and is equipped with turntables so that this group of three rooms may be self sustaining to a large extent.



FIG. 45 (right). Interior of the announcer's booth which adjoins radio master control. Through the window may be seen the control room, and through the further window the lobby with interested visitors looking in.

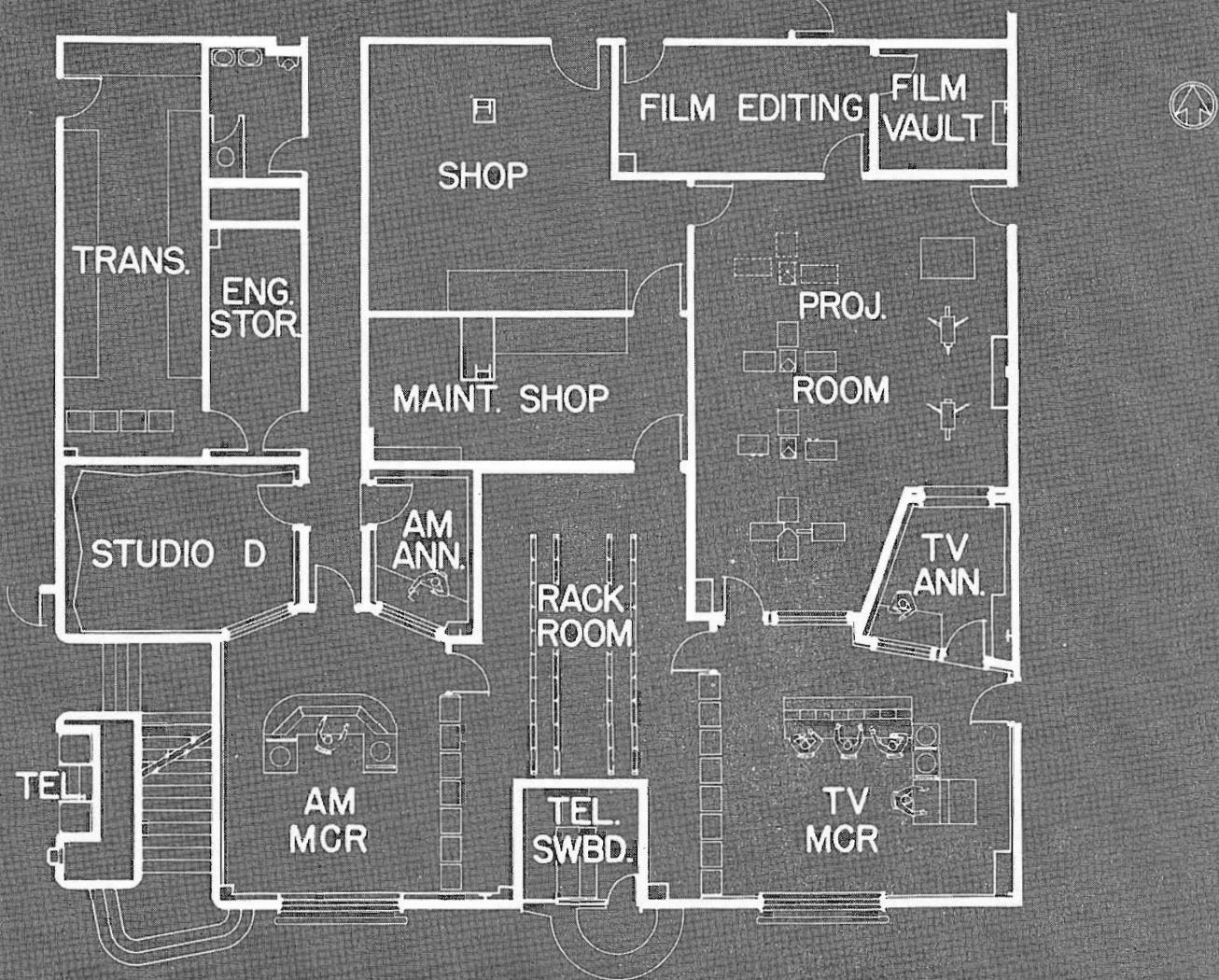

FIG. 46. Floor plan of the technical operations block. The location of this area in the overall plan of the building is indicated on Fig. 4 and Fig. 14. In addition to the obvious advantage of concentrating technical operations, this block, which is a complete self-contained program center, can operate independently when all other parts of the building are closed for the night.

## SELF-CONTAINED "OPERATIONAL BLOCK" AN OUTSTANDING FEATURE

The group of rooms adjoining the lobby and bounded by three corridors is referred to as the "operational block". This block contains all of the elements needed for network and incidental programming for both AM and TV. Early morning and much of the evening operations can be handled here with the rest of the building shut down. This reduces the need for stand-by studio crews and allows the air-conditioning to be turned off in all other zones of the building.

The floor plan of the operational block is shown in Fig. 46, above. The independent operation of the AM master control and its satellite studios has been described on the preceding page. The TV master control can also function as an independent program unit. The TV Announce

Booth has an optical glass window on the projection room side. A "live" camera in the projection room can be directed on this window and will pick up a picture of the announcer in the booth. In this way it is possible to handle news, live commercial spots and any similar type of program without lighting a studio and providing a studio crew. A second "live" camera in the projection room is used with the news picture machine (for reproducing from opaques). In addition there are three RCA TK-20A Film Cameras. Two of these film cameras are arranged to pick up from four RCA TP-16 Film Projectors. The third is provided with a multiplexer so that it can be used with any one of three slide projectors or with a Grey Telop. The camera controls for all five of these cameras, together with camera switching facilities and match-

ing audio facilities, are located in the TV master control room (Fig. 38). Thus it is possible to handle from this point, (1) any type of film show, (2) station breaks and commercials on slides, (3) live newscasts.

The film editing and storage space is located next to the projection room so that incoming news pictures can be made ready for projection in the shortest possible time. Similarly, the recording-transcription storage room is next to Studio D, so that carrying transcriptions up and down halls is largely eliminated. A well-equipped shop is also a part of the operational block. All of the rooms in the area are not only grouped closely but are provided with a large number of doors, so that it is possible to move quickly and by short paths from one part of the area to another.

The lighting in the TV MCR and projection room is entirely functional and consists of shielded lamps suspended from the ceiling on three-foot flexible shafts. They are placed so that lights are directed to any operations requiring them, such as threading projectors and operating relay switching. The remainder of these rooms is relatively dark which permits good viewing of the video monitors.

### RACK ROOM

All of the rack mounted equipment for AM and TV MCR operation is concentrated in one room between the two control rooms. Standard racks form the partitions between the rack room and the respective control rooms and contain the equipment requiring adjustment or observation. The remainder of the equipment is mounted on tee irons extending from the floor trenches to the ceiling. The racks are spaced about 4 inches to permit good wiring, particularly co-ax cable and are operated without front or back doors. This concentration of equipment in one room has three advantages: first, it facilitates installation and later operating maintenance; second, it concentrates power load for efficient wiring and switching; third, it concentrates the heat load for air conditioning purposes. This room is exhausted separately and the major part of the heat loss normally present in master control rooms will be taken care of because the backs of the control room racks are actually in the exhausted room.

### WIRING

There is a considerable concentration of wiring in this building because of AM and TV operations, audition rooms and administrative offices under a single roof. Flexibility and ready access has been provided both for installation and future use. All of the engineering spaces in the operational block, TV Control room and AM studio areas have 4 inch by 15 inch trenches connecting equipment locations in each room and connecting one room to another. Office areas have under-floor duct with high and low tension compartments. Expanded metal Cope duct in various sizes is used to bring camera, microphone and other cables from TV studios to the control rooms and to connect the TV control room and AM studio areas with the respective master control rooms. The three systems are supplemented with conduit wherever required and are tied together horizontally, and with vertical risers, in several parts of the building.



FIG. 47. View of part of the projection room in the WCAU building. There are three film cameras and two "live" cameras in this room. Floor layout is shown in Fig. 46 (opposite page). Three 17-inch receivers, mounted overhead at left, are used as monitors on film camera pickup. Monitor speakers associated with each projector-camera group are suspended from the ceiling so that projectionist can hear the sound pickup above other room noises.

FIG. 48. Cope expanded metal duct is used to carry camera and microphone cables from TV studios to control rooms. Standard elbows and other fittings make it possible to assemble and mount these ducts in a variety of ways. View at the right shows duct running around studio wall.

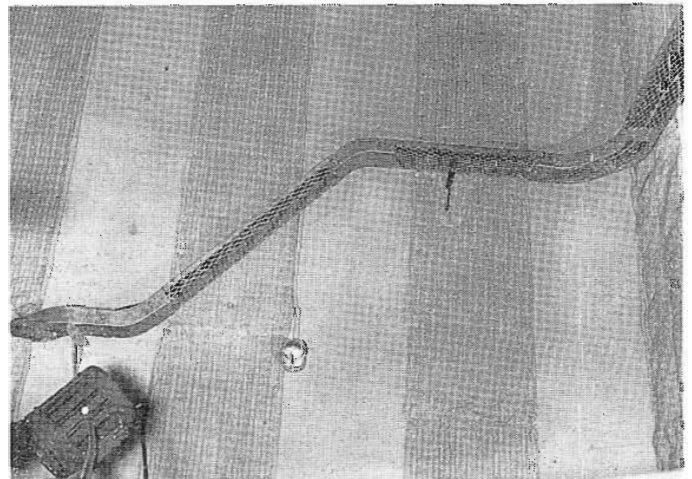
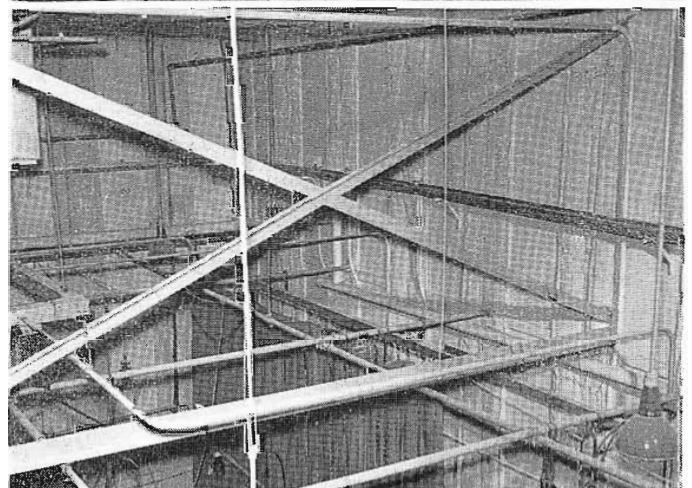
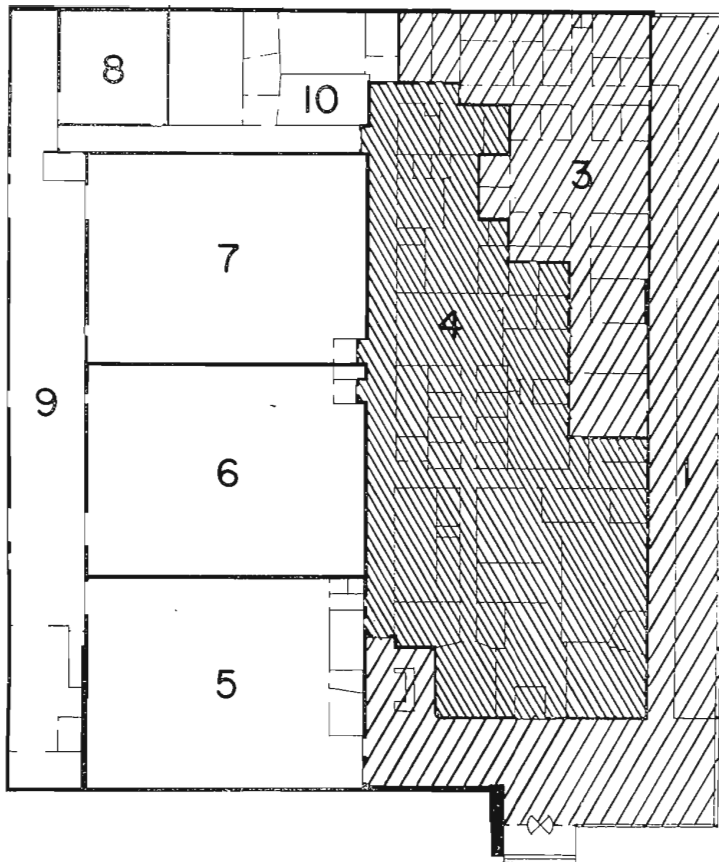

FIG. 49. One system of Cope duct runs around the top of each studio in the Tele-Truss area (middle of the picture at right). Short runs from this duct to fixtures are made with standard conduit. Open top of the duct allows cables to be changed or added very easily.





**AIR CONDITIONING**  
 ▨ 8 A.M. TO 6 P.M.  
 ▤ 24 HOURS  
 □ 8 A.M. TO 7 P.M.

FIG. 50. This floor plan indicates how the air-conditioning system in the new WCAU center may be shut down in three stages. In Area 4, which includes the "operational block" and the news room, activity goes on around the clock and this area is, therefore, air-conditioned all 24 hours. In the lobby and offices (Areas 1 and 3) the air-conditioning is turned off at 6.00 P.M. In the studio part of the building (Areas 5 to 10) the cut-off is normally 7.00 P.M. However, if there is an evening studio show, the air-conditioning in this zone is left on until the last show is over.

## ZONE TYPE AIR-CONDITIONING SYSTEM IN NEW WCAU STUDIO BUILDING

The air conditioning system installed at WCAU was specially designed by the Austin Company to provide for the varying operating conditions which occur during the course of the day and the seasons of the year. Thus, no matter how great or how small the cooling (or heating) load the right temperature is automatically provided in every part of the building.

The main installation consists of two 200-ton refrigeration compressors. The cooled air is distributed through eleven separate air conditioning systems. Each of these is, in turn, sub-divided into a number of smaller zones, each with its own thermostatic controls.

Each of the three large TV studios, together with its control room, announcer's booth, and client's booth, for instance, is served by a single system which has six separate control zones.

One zone maintains proper temperature in the announce and control booths; a second serves the sponsor's booth, and the other four provide the cooling—or heating—required at the particular moment in each quarter of the large TV staging area.

This studio cooling varies greatly because of the heat emitted by the special lighting. In winter, for example, warm air might be needed in three zones, while cool air is needed to counteract the heat in the fourth quadrant.

The entire system is so designed that the air conditioning may be shut down in three stages. In the core of the building, where 24-hour broadcasting goes on, the air conditioning is operated around the clock. For the TV studio section, it may be shut down separately. The same applies to the office area, where ordinary business hours are in effect.

Because broadcasting studios must be entirely free of extraneous noise, all the piping was installed with special rubber sections which damp out the transmission of vibration from room to room. The refrigeration compressors and all the other mechanical equipment are mounted on separate foundations with rubber isolators, so that any vibration created by moving parts is absorbed before it creates noise.

Likewise, all the sheet metal air conditioning ducts were designed with special

sections of flexible asbestos cloth at the fan inlet and outlet connections, and at the point where they enter the studio areas.

The building is heated by two Scotch boilers which burn No. 6 fuel oil. The heating system uses hot water heating coils and warm air is circulated through the same ducts used for air-conditioning. The only radiation is along the north wall of the office wing to neutralize the outdoor cold on this one side during the winter months.

The insulating and acoustic work was done by the Johns-Manville Corporation. Standard forms of insulation and isolation are used. Acoustic treatment is a combination of rock-wool blankets, isolated walls and serrated surfaces. Each TV Studio has rock wool treatment over 50% of the side walls and 100% of the ceiling area. No attempt was made to cover the rock wool blanket except in portions of the audience studio where damage might be experienced, if exposed. All windows in the studio area were considered and the panes angled for minimum sound and light reflections.

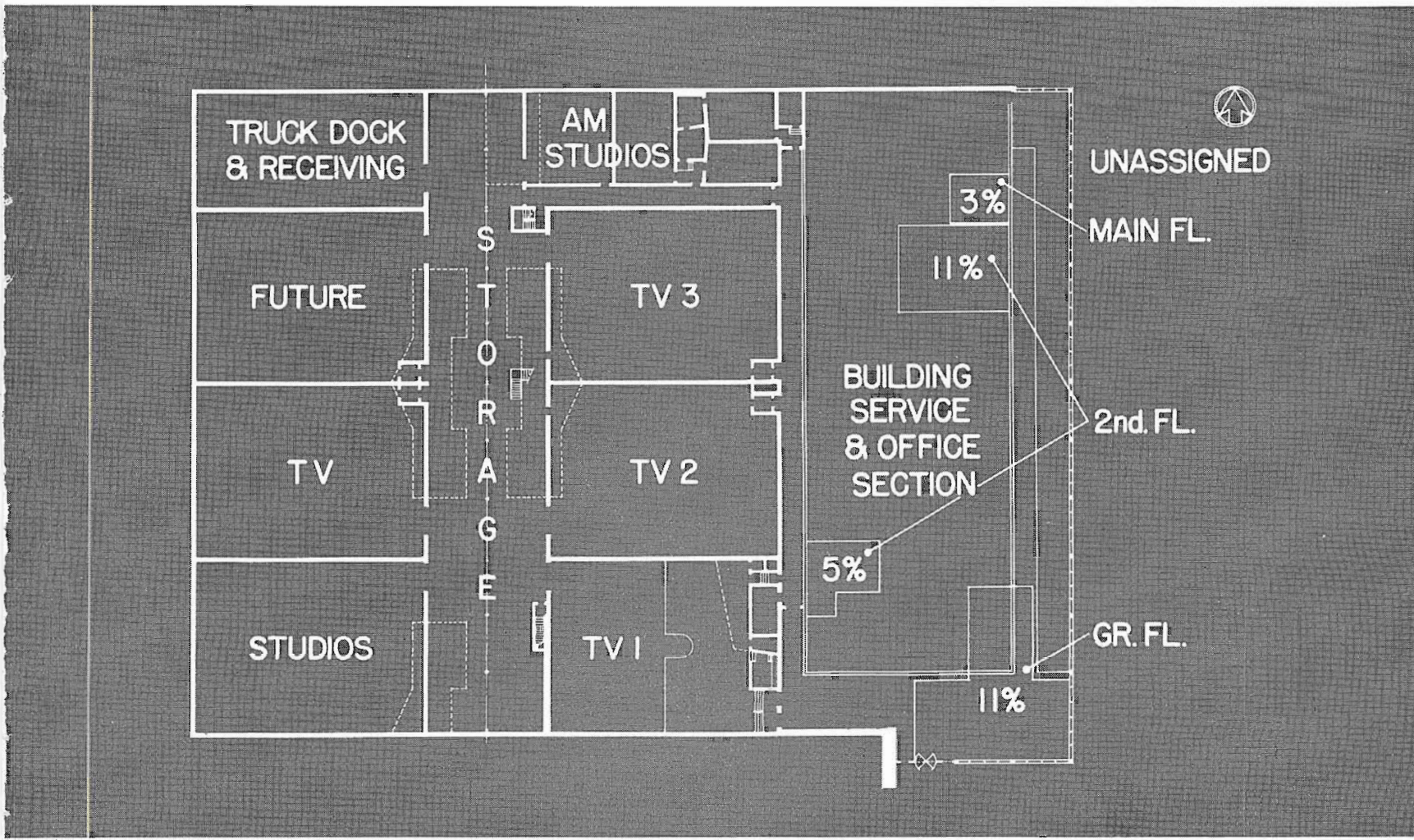

FIG. 51. Floor plan for future expansion of the WCAU center by addition of three more large studios. This would be done by building a new wing to the west of the building on land which was secured with this in mind (see Fig. 2).

## PROVISION FOR EXPANSION OF WCAU STUDIO BUILDING

The plan used permits orderly expansion of TV studio facilities if the future requires it. The same truss construction may be used, the plan turned over and the present building extended to the eastward. The TV storage area remains a common

space for all TV studios and all of the control rooms are concentrated in the same area and on the same level.

There is a calculated amount of unassigned space on each floor of the office

section which permits reasonable expansion but does not result in too great an area of non-productive space. The presently unassigned area is about 30% of the total floor space or an average of 10% per floor.

FIG. 52. Cross section showing how new studios would be back-to-back with present studios so that storage area would be common and would have direct entrances to all six TV studios.

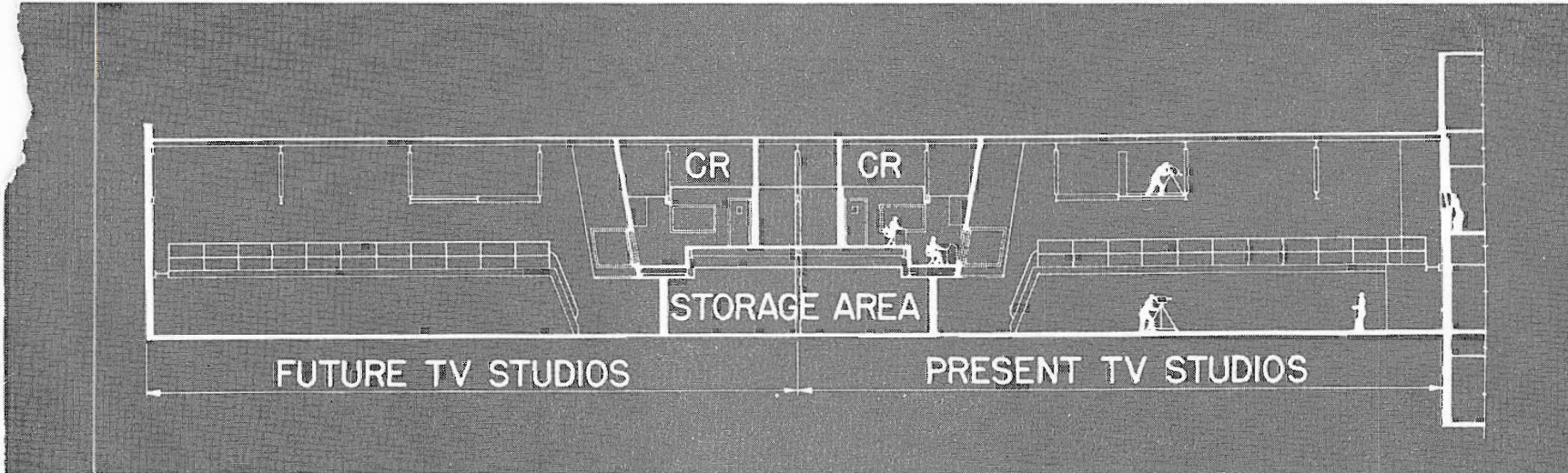

# PRACTICAL APPLICATIONS OF MICROPHONES FOR TELEVISION

By **H. M. GURIN**  
Engineering Department  
National Broadcasting Company

At the present time in many parts of the United States, plans are being made for setting up television services and means are being sought for overcoming the many technical, artistic and economic difficulties.

Perhaps understandably, nearly all effort is being devoted to the difficulties that are

peculiarly visual ones, and the transmission of the sound component of the television programs is often looked upon as presenting no special problem. This may be because the organizations planning television services have had many years experience of broadcasting sound programs and tend to

assume that the technique is the same, or at any rate, similar.

This assumption is far from being true, however, for while in sound broadcasting it is usual to use a studio having an acoustical performance at least approximately appropriate to the program; to allow in the studio only the actual performers; and to arrange the microphones in optimum positions relative to the performers; in television it is generally impracticable to do any of these three things. The acoustical performance of the studio is modified in an unpredictable and changing manner by scenery, cameras, and lighting equipment to say nothing of the large number of technicians and other persons necessarily present in the studio. For the same reasons the noise level is usually high, especially so, by broadcasting studio standards and it is furthermore very rare to be able to arrange the microphones reasonably close to the speakers. These shortcomings have made it necessary to study the problem of the sound component of television programs and to develop special techniques.

In the formative stages of television in which we are apparently involved, it has been commonly accepted that the sense of sight is more important than hearing and that, in general, more pleasure can be obtained through seeing. It is fortunate, at least for the present, that the picture commands so much of the viewers' attention because so many problems confront the sound engineer in his efforts to obtain

FIG. 1. The RCA 77-D . . . useful as a boom microphone as well as a desk or floor-stand microphone.



FIG. 2. Boom microphone in center of studio with multiple sets.

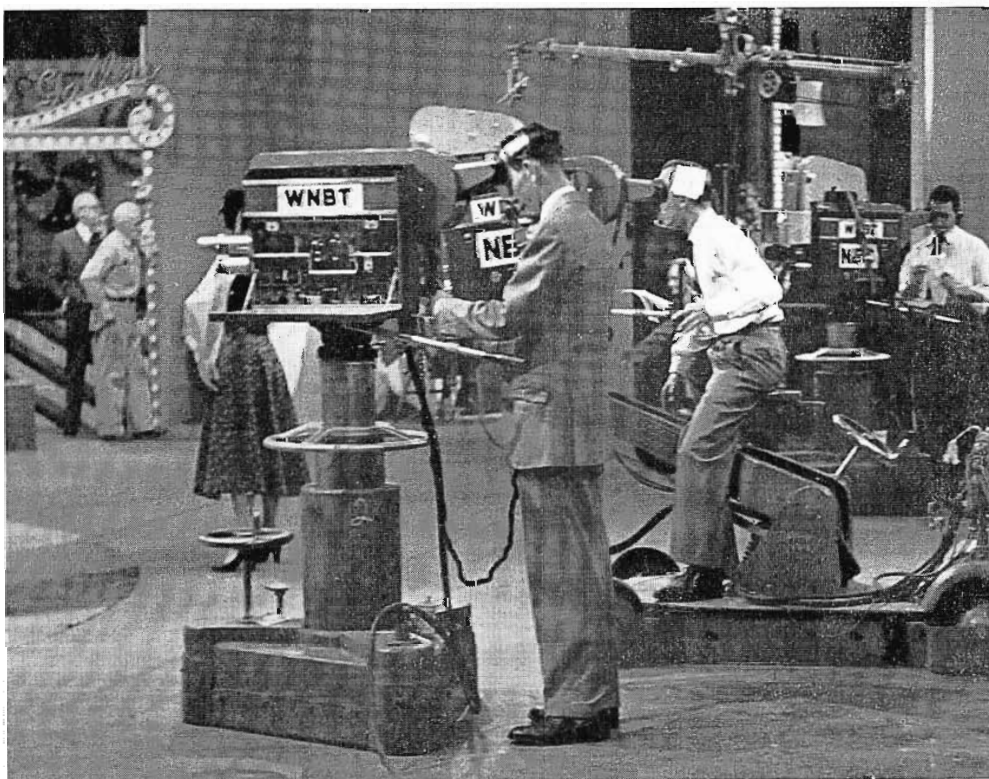

TYPE 77-D MICROPHONE (UNI-DIRECTIONAL POSITION)

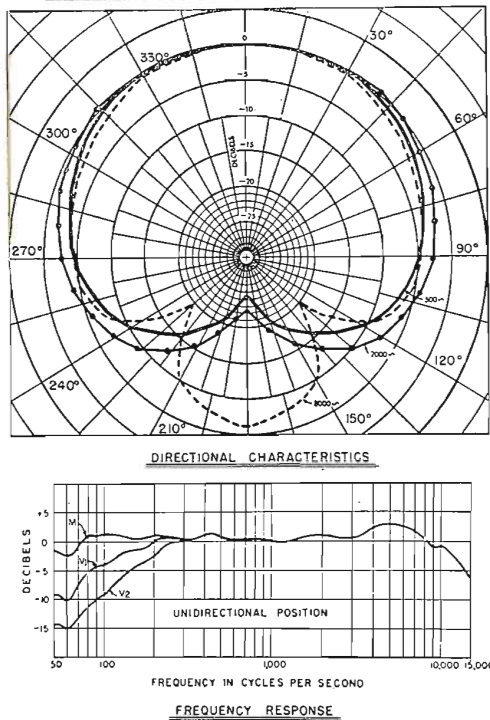

FIG. 3. RCA Type 77-D frequency response and directional pattern.

satisfactory sound that it usually is impossible to get the best results and a compromise must suffice. The quality of the sound reproduction has therefore frequently been inferior to that which we have become accustomed to hear in standard sound broadcasting.

The chief aim of the studio engineer is to produce good quality sound which is usually a fitting accompaniment but not necessarily subordinate to the picture. In sound broadcasting, the microphones and performers can be placed wherever it seems best from these considerations. On the other hand, in television the sound source may move continuously without consideration of directivity or sensitivity of the microphone. Moreover, the microphone and its shadow must remain almost always out of sight of the cameras. The desired relationship can therefore be attained only by adopting techniques which permit the sound to be picked up at an infinite number of angles and distances and yet be completely and instantaneously controlled.

The microphone techniques applicable to television depend on the type of programs which may be classified in three general groups:<sup>1</sup>

1. Programs in which the appearance of the microphone would be completely out of place or too distracting; as in

dramatic shows, large variety programs, special interview programs where an air of spontaneity and informality is required, etc.

2. Programs in which a limited number of microphones are visible and others are not; as in amateur programs, some musical programs, or certain quiz programs.

3. Programs in which the visual presence of a microphone or microphones is accepted as part of the program; as in panel discussions, news reporting, interviews, concert and dance orchestras, sporting events, etc.

In the last group, the microphone techniques are, in general, similar to normal sound broadcasting practices which have been amply and well documented elsewhere.<sup>2</sup> One important requirement, however, has been added—namely that the microphone must not obscure the artist or principal subject.

A television studio production, once started is continuous and is carried on over the entire studio area. It is therefore essential to employ some method capable of picking up sound from any part of the acting area and usually without having any microphone in view. The normal and, so far, the best solution, is to use a unidirectional microphone suspended from a boom.

<sup>2</sup> H. M. Gurin—"Broadcast Studio Pickup Technique"—Audio Engineering, February 1948.

The RCA 77-D shown in Fig. 1 has played the versatile role of boom microphone as well as desk or floor stand microphone. The operator must be able to cover large acting areas with a single microphone, and follow the performers as they move about—a typical illustration is given in Fig. 2. Typical boom microphones are arranged so that from one position of the boom the microphone can be rotated approximately 270°; moved a distance of ten feet; and can swing in an arc of 280° with a continuously adjustable radius from 7' 0" to 17' 0". In addition it can be raised and lowered from approximately 12' 0" to 4' 0" respectively. The microphone is thus capable of occupying a multitude of positions in a rather large solid angle.

The necessity of keeping the microphone out of the picture itself in the majority of programs, means that it has to be located further from the source of sound than would normally be the case in sound broadcasting. This consideration suggests the use of a unidirectional microphone which is most satisfactory in rejecting noise from every direction except that to which the microphone is pointed. The factor is particularly important since much of the unwanted noise originating in a television studio usually comes from behind the microphone and is created by camera movements, scenery shifting, adjusting lights, and general movement of actors and technicians.



FIG. 4. Experimental highly directional gradient microphone—boom mounted—developed by Olson, Preston and Bleasey of RCA.

<sup>1</sup> W. M. Baston—"Television Microphone Techniques"—BROADCAST NEWS, Vol. 66, p. 18.

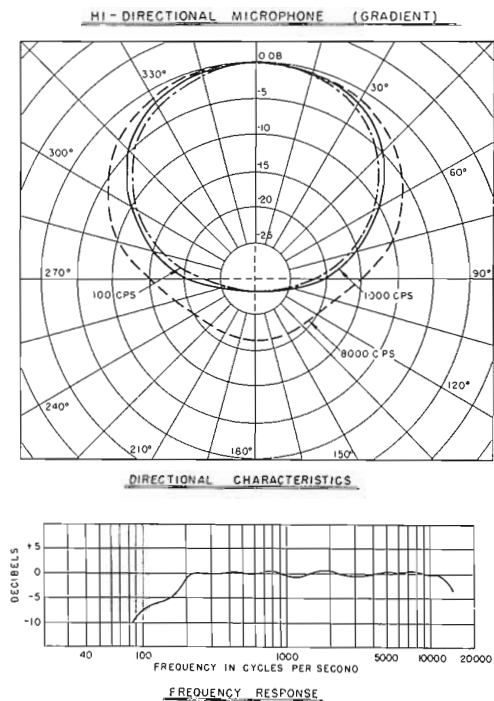

FIG. 5. Gradient microphone frequency response and directional pattern.

When sound is generated in a space, the collecting system via the microphone is generally so oriented that the first sounds come from the source directly and are followed by the sound reflected from surrounding surfaces. The ratio of reflected to direct sound is considered the effective reverberation of the collected sound. The proportion of reflected to direct sound in a pickup is determined only partly by the

acoustical characteristics of the studio. The directional character of the sound source and the receptive angle of the microphone used as well as its distance from the source are also important.<sup>2</sup>

The use of a unidirectional microphone is particularly desirable because it tends to reduce the ratio of reflected to direct sound thereby keeping the apparent reverberation to a minimum. One of the most commonly used microphones is the RCA type 77-D, whose characteristics are shown in Fig. 3. Even with the cardioid pattern of present day microphones the front-to-back pickup ratio is not entirely satisfactory.

Encouraging strides are being made in this direction, however, with the development of a gradient microphone designed and built by Dr. Olson, Mr. Preston and Mr. Bleazey, of The David Sarnoff Research Laboratories at Princeton, N. J., and recently adapted, on an experimental basis, for boom mounting which has a highly directional pattern. Fig. 4 shows its physical appearance and Fig. 5 shows its directional pattern and frequency response. It is hoped that the use of this microphone will permit operation at greater distances from the sound source without seriously affecting the sound quality and thereby permitting greater freedom of movement for the performers as well as reduce the occurrence of boom shadow or visual interference.

It should be evident how important are the duties of the boom operator. He constantly has to bear in mind the actual dis-

tance from the sound source to the microphone and to foresee the effect on the apparent reverberation of the space in which the sound and microphone combination are exerted as well as keeping the microphone, the boom and their shadows out of the picture. The sound quality frequently depends on his initiative and acoustical reactions.

The scenes taken by a TV camera will range from a close-up to wide angle shots so that a boom microphone positioned for good sound pickup on a close-up may be in the picture on a medium or wide angle shot as can readily be deduced from Fig. 6. In usual studio practice the audio engineer previews the picture on a TV monitor and advises the boom operator over an inter-communication system of the position of his microphone and warns him of any likelihood of the microphone encroaching into the picture. If such danger is present, as it frequently happens, the boom must be raised or shortened—"racked in"—resulting in a marked change of sound quality. This situation is usually taken care of by compromising the microphone position so that it is not too near the performer for the close-up and so when it is moved away the change is not too pronounced.

Frequently a television production is spread so widely that it is impossible to cover every acting area with a single boom and several may be required or the boom supplemented with other microphones, which are suspended from fixed locations or built into the scenic design. Great care

FIG. 6. Typical scene where boom must be raised rapidly from seated figure to rising position for wide angle pictures.

FIG. 7. RCA 77-D microphone compared to the RCA KB-2C for desk mounting.





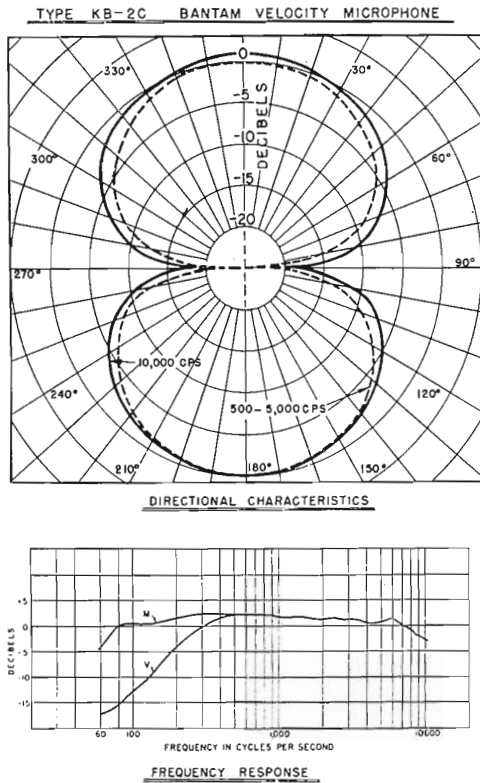

FIG. 8. KB-2C frequency response and directivity pattern.

must be taken when using microphones in this manner to match the effective frequency response, and thereby avoid a change in sound quality when a switch is made. It is also important that the transfer from one to another and the use of concealed microphones be restricted to a minimum since the quality of reproduction is seriously affected by their proximity to a variety of surrounding surfaces and objects which could result in wave interferences and undesirable phasing effects.

Stimulated by the need for small and easily disguised microphones, a number of unobtrusive pickup devices have been developed.<sup>3</sup> One of these is the RCA model KB-2C, or miniature velocity microphone, which, without sacrificing its acoustical properties, is small enough to be hardly noticeable if carefully blended with the surroundings. Fig. 7 shows its actual physical appearance when compared with an RCA-77D, both mounted for desk or table use and Fig. 8 shows its directional characteristics and frequency response. Because of the KB-2C's bidirectional pattern some care must be exercised in its use but if the ratio of direct to reflected sound is large enough it can be used to excellent advantage.

A very small ribbon type pressure microphone has also been especially designed for

<sup>3</sup> L. J. Anderson and L. M. Wiginton—"The Bantam Mike—KB-2C"—BROADCAST NEWS, Vol. 58, p. 14.

television work and has been designated as the Starmaker, RCA Type BK-4A.<sup>4</sup> Its small size and slender construction afford easy concealment or an unobstructed view of its user in close work. The microphone is finished in a dull gray to minimize undesirable highlights. Its physical appearance and the directional characteristics as well as its frequency response are shown in the next two Figs. 9 and 10. This microphone has proved to be particularly suitable in audience participation shows where the announcer carries the microphone to someone being questioned or interviewed and in informal discussions as seen in Fig. 11. The same microphone can be very conveniently worn, as seen in Fig. 12, without detracting attention from the wearer.

The nondirectional microphone must be used cautiously because of the possibility of too high an apparent reverberant effect caused by a disproportionate ratio of reflected to direct sound and the lack of ability to discriminate against off-the-set noises. Such microphones can be employed safely only on very closely grouped subjects.

A new experimental uniaxial microphone has only recently been completed by RCA. Its appearance and characteristics are shown in the next two Figs. 13 and 14 respectively. Microphones like these having narrower receptive angles and being so compact should prove particularly useful when used for speakers' stands and general conference tables.

Experience has indicated that a certain amount of low frequency attenuation can be tolerated in microphones which are used principally for speech or required to move rapidly, without appreciable loss in acceptable quality. Such attenuation is particularly helpful in minimizing studio background noise, rumble, and actually helping intelligibility. Accordingly, most of these microphones can be used successfully when the frequency response rolls off below 100 cycles. Fig. 15 shows a summary of the characteristics of the foregoing pickup devices.

One of the most serious problems faced in microphone placement for television is to make the sound accompanying the picture suit the apparent distances shown. Two means are available in achieving this "sound perspective." One is by controlling the apparent reverberation either electrically by the use of filter circuits or through an echo chamber and the other is by control of the volume or loudness level. Thus if a camera is to be used to take a long

<sup>4</sup> New "Unobtrusive" Ribbon—Pressure Microphone"—BROADCAST NEWS, Vol. 59, p. 24.



FIG. 9. Starmaker microphone.

shot the volume of sound associated with the picture is turned down an appropriate amount to produce the desired psychological effect and the reverberation control opened to give an increase in the apparent reverberation effect. Another scene taken as a close-up would require more direct sound and full volume. Such a system implies an automatic switching arrangement between camera with their turret lenses and audio controls and is necessarily complicated, re-

FIG. 10. BK-4A frequency response and directional pattern.

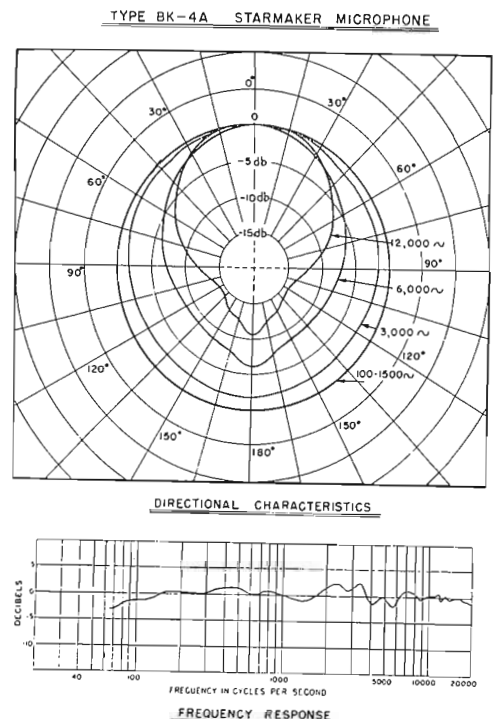

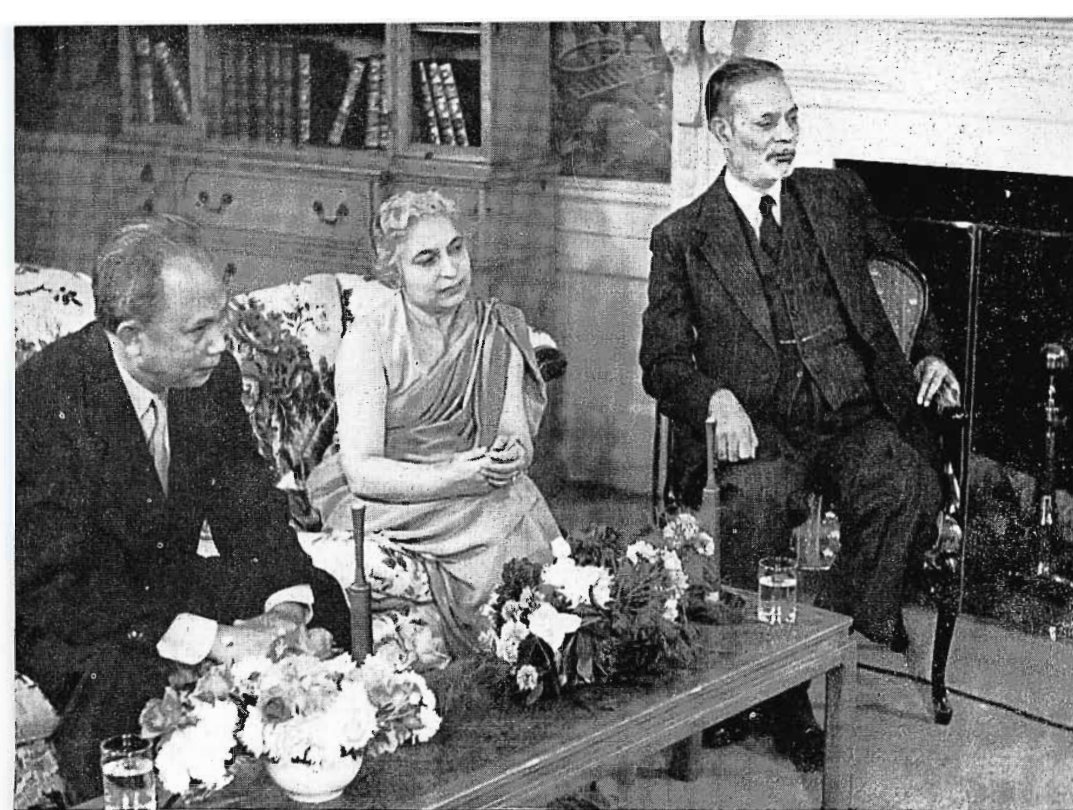

FIG. 11. Starmaker microphone used for informal discussion program on NBC.

quiring great skill and long rehearsals to avoid ludicrous effects which might completely nullify the intent of the picture itself. Very often a solution is automatically obtained by merely raising the boom microphone far enough out of the picture to give the desired overall reaction. Careful planning is required, however, in giving the microphone time to return to the best position for a close up which may follow almost immediately so as not to lose any sound during the transition.

It has long been recognized that ideal television studio should be able to provide many different acoustical conditions varying from outdoor scenes to interior of large

FIG. 12. Starmaker microphone worn by Dave Garroway—NBC.



halls and small living rooms. While the current practice in most instances is to keep the actual reverberation characteristic as low as possible and introduce "liveness" by use of flats in the scenery, musical productions are handicapped. In large studios particularly, trouble is experienced in timing and hearing one another if the performers are too far from the orchestra. This can be overcome by giving the conductor his own monitor to synchronize properly the music to the action and a headphone circuit carrying the voice. In some productions, which do not require that the orchestra be seen, the difficulty of low reverberation in the TV studio can be overcome by putting the group in a "sound" studio and relaying the sound to the television studio program mixer with monitoring loudspeakers in the TV studio itself for the artist on camera. This has many advantages, for in general, playing conditions for the musicians are now more suitable, the quality of reproduction can be better and an improved balance between orchestra and performer is possible. While other production difficulties may arise, this technique has been used with great success on many occasions.

Another attempt to overcome the difficulty of balancing speech and music in television was the adaptation of pre-recording of the sound component. Good results have been obtained but considerable rehearsal time and recording sessions are involved. This method can sometime be used to excellent effect for short sequences.

In the past two years, more and more television programs have originated in theatres. While camera movement becomes

more restricted since the major point of view is from the auditorium, the problem of following the sound on stage is not lessened. Microphone booms are normally placed in the wings but constitute a hazard by their presence to the entrance or exit of the performers as seen in Fig. 16. In addition, the depths of some stages are such that the booms cannot readily reach every point. An attempt to solve this problem was made by moving the booms downstage to cover the middle portions and adding several rising 77-D microphones from fixed positions at the edge of the stage to cover the forward or upstage section. The rigid location of these footlight microphones, however, restricted the mobility of the performers in the most important acting area so greatly that a unidirectional microphone was suspended to a tubular trapeze which could be raised or lowered and travel across the stage to follow the artist. This system required the help of an additional operator located in a position with good visibility of the entire stage who could select the proper microphone, control its height and/or move to its proper position. His function was separate and distinct, but associated with the sound engineer who controlled the overall level and the balance between the performer and orchestra. The plan was deemed unsuitable, however, because action was confined to planes which limited the freedom of movement and was unsatisfactory in collecting the sound when a transition in depth of the stage was involved. The incident is worth mentioning, however, to help others avoid similar experiences.

FIG. 13. Uniaxial microphone and the RCA 77-D as desk microphones.



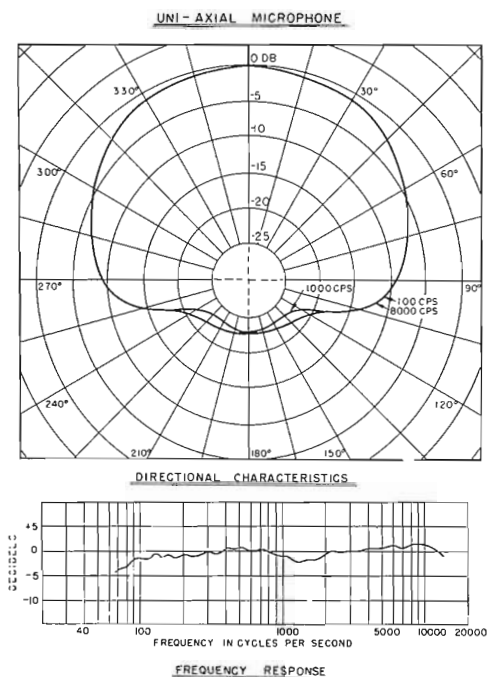

FIG. 14. Uni-axial microphone directional characteristics and frequency response.

It has been suggested that the use of a large number of fixed overhead microphones with highly directional patterns, similar to the gradient microphone previously described, and strategically placed might offer a possible solution.<sup>5</sup> Some experiments using a limited number, three to be exact, in fixed locations were conducted and the results compared with a boom microphone. The action was confined so that the moving sound source did not exceed fifteen feet from the fixed mikes while the boom mike remained from three to six feet from the sound source in accordance with normal operating procedures. The results indicated that the boom was preferable while it operated at its normal distances as compared to the fixed microphones operating at distances of twelve to fifteen feet. The greater apparent reverberent effect obtained with the gradient microphones at these distances was the principal objection. It must be admitted that since these tests were performed, the directivity and sensitivity have been improved and that in the hands of a skilled operator with more microphones, the results today might be entirely different. In any case, the investigation for improving theatre pickup is continuing.

It should be emphasized that no hard and fast rules can be laid down for TV audio techniques since each situation must be explored for its full potentialities. In all cases the final criteria of achievement

<sup>5</sup> H. F. Olson and J. Preston—"Directional Microphone"—RCA Review, Vol. X, No. 2, Sept. 1949, pp. 339-347.

TABLE I GENERAL PROPERTIES AND CHARACTERISTICS OF MICROPHONES USED IN TELEVISION					
MODEL	TYPE	FREQUENCY RESPONSE	OUTPUT IMPEDANCE	OUTPUT LEVEL 1000 CYCLES	DIRECTIONAL CHARACTERISTICS
77-D	COMBINATION RIBBON VELOCITY AND PRESSURE	30-15,000 ± 5 db	50/250/600	-57 dbm	UNIDIRECTIONAL
UNI-AXIAL	"	60-15,000 ± 2 db	250	-58 dbm	"
H I DIRECTIONAL	PRESSURE RIBBON GRADIENT	100-15,000 ± 5 db	250	-55 dbm	"
KB-2C	RIBBON VELOCITY	80-10,000 ± 4 db	30/150/250	-56 dbm	BIDIRECTIONAL
BK-4A	RIBBON PRESSURE	70-15,000 ± 3 db	30/150/250	-60 dbm	NON-DIRECTIONAL

•• SOUND PRESSURE - 10 DYNES / Sq. cm.  
\* mfr SPECIFICATIONS.

FIG. 15. Table I summary of general properties and characteristics of television microphones.

is the creation of any effect which is judged to be most satisfactory from all standpoints. Television, as a medium which combines sight and sound for entertainment and information, can best be served by the intelligent compromise between pictorial requirements and the audio pickup techniques. The ideal program would of course combine the best audio pickup with the most suitable visual effects for the fullest appreciation of the material presented.

To acknowledge separately the contributions of all the individuals at NBC and

RCA who continue to be active in improving TV sound would not be feasible but special mention should be made of the encouragement and direction given to this program by Mr. O. B. Hanson, Chief Engineer and Vice President of NBC, to Mr. W. Baston, for contributing much of the information contained herein, to Dr. Olson and his staff at the RCA Laboratories for their efforts, and to the RCA Victor Division for its part in making available the instruments upon which the success of this work depends.

FIG. 16. Typical boom location in wings of an NBC-TV theatre.



# TYPE BHF-50A 50KW HIGH FREQUENCY TRANSMITTER

The BHF-50A transmitter is a 50 KW AM High Frequency broadcast transmitter designed for high fidelity service in the International Broadcast bands from 3.9 to 26.1 megacycles. The transmitter is entirely air cooled. The number of tuning adjustments are held to a minimum by the use of grounded grid amplifiers and by the use of ganged circuit elements. The use of remotely controlled motor driven circuit elements permits tuning the transmitter to any frequency within the range of 3.9 to 22 megacycles within an elapsed time of 2 minutes, with slightly longer time required for changing to the 26.1 band. Features include a unified front, streamline styling, centralized power and control units, and dead front construction.

## Mechanical Features

A plan view of a typical layout of the BHF-50A is shown in Fig. 1. The front panel is 84 inches high and 16½ feet long. The r-f section of the transmitter is placed

By **C. J. STARNER**  
Transmitter Engineering

behind this panel with the exciter and modulator to the right and the 50 KW amplifier and output unit to the left. The 50 KW amplifier is built as one unit comprising the driver and final amplifiers. This amplifier unit, together with the output unit, is set back from the front panel to provide a walkway for inspection, tube changing, etc. Tube changing is facilitated by providing a tube hoist for the 50 KW amplifier tubes, and by the use of quick acting tube connectors.

Tuning controls for the low power r-f stages are located on the exciter unit front, as are the indicating instruments for these stages. Tuning controls for the 50 KW amplifier are centralized on the center section of the front panel together with the indicating instruments associated with these

controls. Normal operational controls are located in this same central position.

Installation flexibility is attained by making the r-f and modulating sections an integral unit with interconnecting wiring ducts provided, and considering the power equipment as items which may be strategically placed to avoid building obstructions. The minimum required "one piece" (back of panel) areas is 9 x 19½ feet, and the power equipment may be located, as desired either on the same floor level or in a basement space. Power equipment is constructed in units entirely enclosed and interlocked so that no fences or enclosures are required, other than that required for the oil filled modulator units by local electrical codes. Interconnecting conduit and wire ducts are held to a minimum by enclosing all the main d-c power supplies oil in one unit.

## Circuit Description

Fig. 3 is a block diagram showing the major components and tubes of the BHF-50A. The exciter unit is housed in a cabinet with front and rear access doors, with all tuning controls and indicating instruments located on the front panel. Three stages of amplification are used to raise the r-f signal from an external source of 1 to 3 watts to the power level necessary to excite the following driver amplifier.

The first amplifier employs an RCA type 4E27A tube operating as a frequency doubler. The external signal is applied to the input circuit of this stage through a 50 to 75 ohm coaxial connection. The plate circuit consists of a variable capacitance and inductance which are ganged and operated simultaneously by the same control.

The second stage (1st RF) has two 4E27A tubes in parallel with ganged inductance and capacitance tuning similar to that used in the doubler stage. The plate

FIG 1. Typical Floor Plan of the BHF-50A showing location of its various component parts.

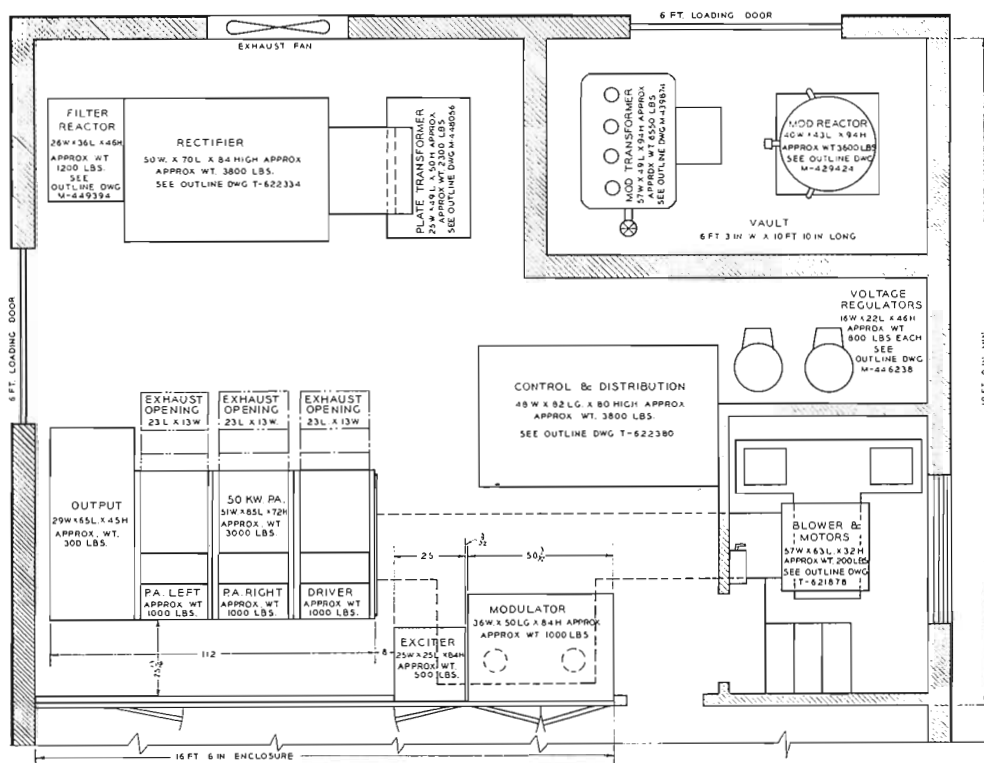

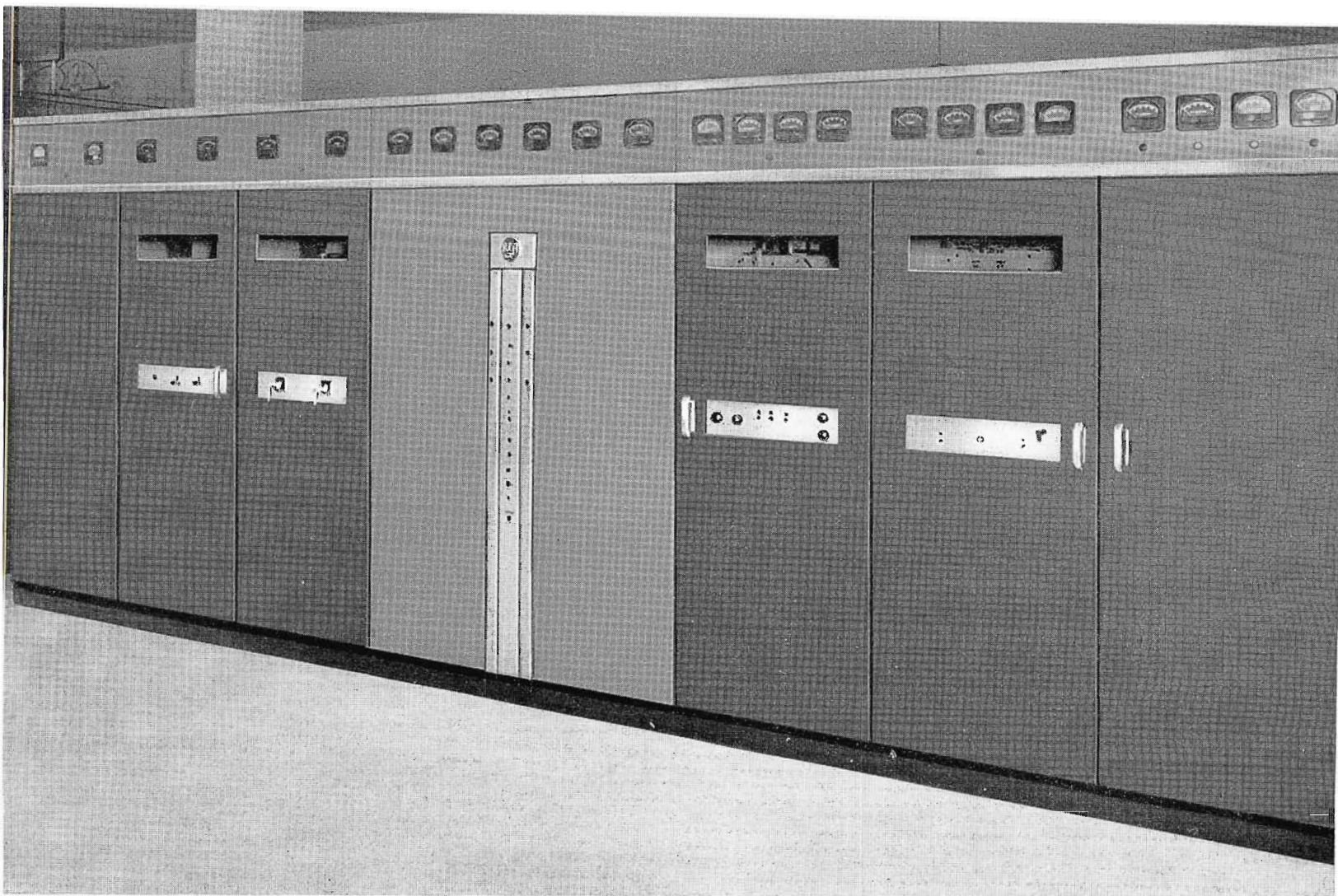

FIG. 2. Front View of BHF-50A 50 KW High Frequency Transmitter.

circuit is a "pi" type filter circuit with the output capacitor variable from the front panel to control the driving power to the Intermediate power amplifier (IPA).

The IPA uses an RCA 5762 external anode air cooled triode, in a grounded grid circuit, and consequently no neutralization is required. The filament is isolated from the 60 cycle power supply by dual chokes and the tube input capacity becomes a part of the output capacitance leg of the 2nd r-f plate circuit. As a result, a low impedance input is assured, and no instability or harmonic resonances were encountered through the use of this essentially direct coupling.

A "pi" network configuration is used for the plate circuit, with the series inductive leg and the input shunt capacitive leg ganged mechanically and front panel controlled. Separate control is provided for the output leg to provide drive adjustment for the driver amplifier. Use of the ganged plate circuit elements and vacuum capacitors allows tuning adjustment over the entire frequency range from a single front panel control.

FIG. 3. Block Diagram of the BHF-50A.

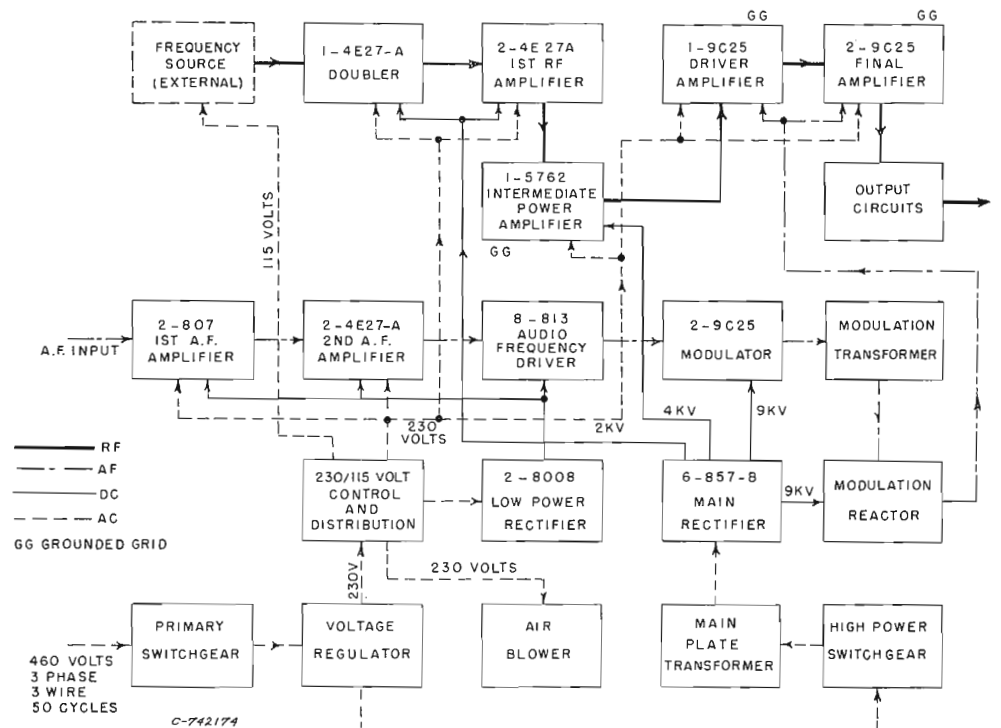

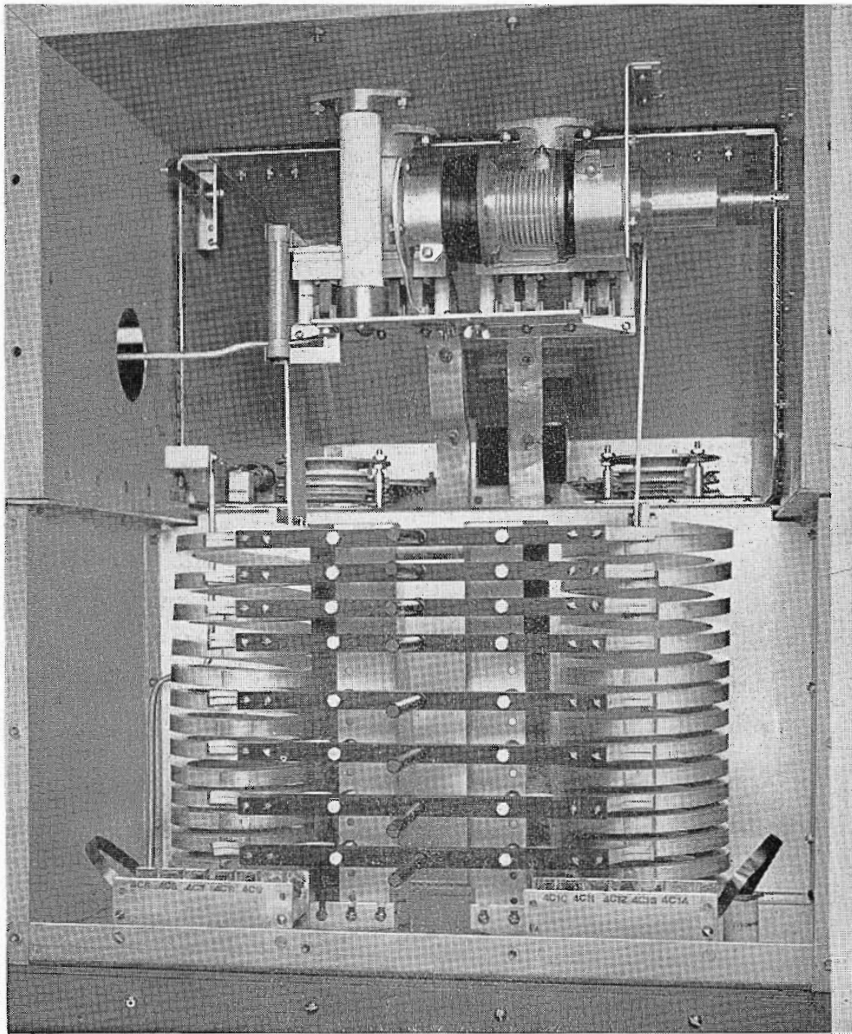

FIG. 4. Final Amplifier Cathode Circuits showing filament series chokes and vacuum-tuning capacitor.

All tuning adjustment drives are mechanical, using gear and chain mechanisms as required. Indicators are either of the pointer type, or, where more than one revolution is involved, the counter type.

The r-f power from the exciter is coupled to the driver amplifier through a 120 ohm, three inch coaxial line, fed from the output leg of the IPA "pi" tank circuit. The effective input resistance of the driver amplifier is approximately 120 ohms when the transmitter is operating at full power, and the driver input circuit is resonant. A considerable variation in the effective input resistance of the driver occurs at the upper frequency range, due to the fact that the feed point is approximately  $\frac{1}{8}$  wave length from the actual driver tube elements. No degradation of performance results from this mis-match, and no provision is included to provide coupling variation at the driver input circuit.

#### Final Amplifiers

These amplifiers are essentially physically and electrically identical, and are identified as the driver amplifier and output amplifiers. All three amplifiers use grounded-grid circuitry, and are all plate modulated. Since grounded-grid or cathode drive is used, and since the a-c plate current must flow through the input circuit, then an additional component of input drive is required (feed-through) which becomes part of the output power. This additional power is controllable within the limits of tube operation and tube bias voltage rating, by the amount of bias used. In this transmitter a high value of bias is used in the two output amplifiers in a deliberate attempt to load the driver and increase its contribution to the transmitter output. In practice, the driver supplies approximately 10 KW of the total 50 KW output, and the final amplifiers the remaining 40 KW.

FIG. 5. Front View of Exciter Unit showing 1st and 2nd R-F Amplifiers and IPA Tube.

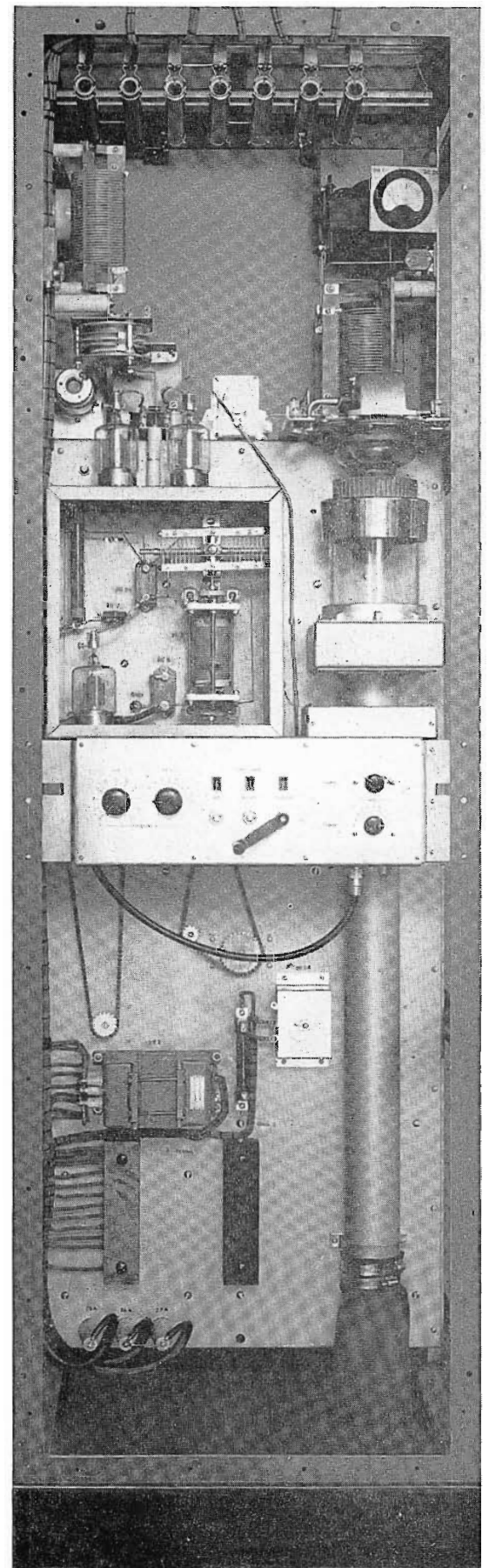
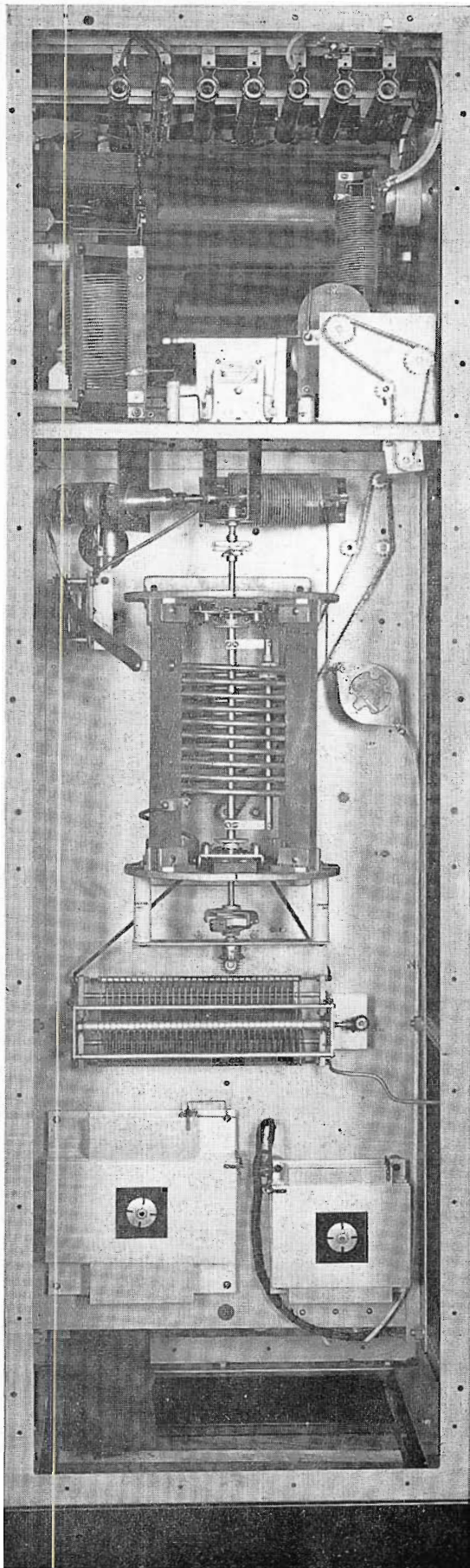

FIG. 6. Rear View of Exciter Unit showing the IPA Plate Circuits



Since the IPA is electrically an appreciable distance from the cathode of the driver amplifier, (in the order of a half wave length at 22 megacycles) it is necessary to provide a low harmonic impedance from filament to ground at the driver amplifier. A tuned circuit is therefore supplied as near to the actual tube filament as is mechanically practical and consistent with easy tube replacement. The filament is isolated from ground for r-f by means of two r-f chokes which are utilized as the inductance for this tuned circuit. A variable, remotely controlled, vacuum capacitor forms the capacitive leg. The circuit is tuned to parallel resonance at the operative frequency thus providing the required isolating impedance for the r-f drive. A KVA to KW ratio of approximately 3 with respect to total driving force was found to be satisfactory from the standpoint of efficiency and taps are used on the filament series chokes to maintain this ratio over the entire frequency range.

At 26 megacycles the coils are entirely shorted, with the filament leads furnishing the total inductance. A considerable 60 cycle voltage drop occurs in these series chokes, (in the order of 0.3 of a volt) and the method of shorting the choke for r-f is so arranged that little or no 60 cycle current flows through the shorting path and the 60 cycle drop is consequently constant regardless of how much of the choke is shorted. A 6 inch length of  $\frac{3}{8}$  inch wide nichrome ribbon included in the shorting path has sufficiently high resistance at 60 cycle, (with respect to the total series choke resistance), that very little 60 cycle current flows through it. The location is such, with respect to r-f currents, that any harmonic resonance which may occur in the shorted portion of the choke will tend to be damped by the resistance of the nichrome ribbon. The entire filament drive circuit is enclosed in a folded cavity, formed in part by the exhaust duct for the tube cooling air. Tuning motors and interlock

FIG. 7. Output Circuit showing inductance and tuning capacitors.

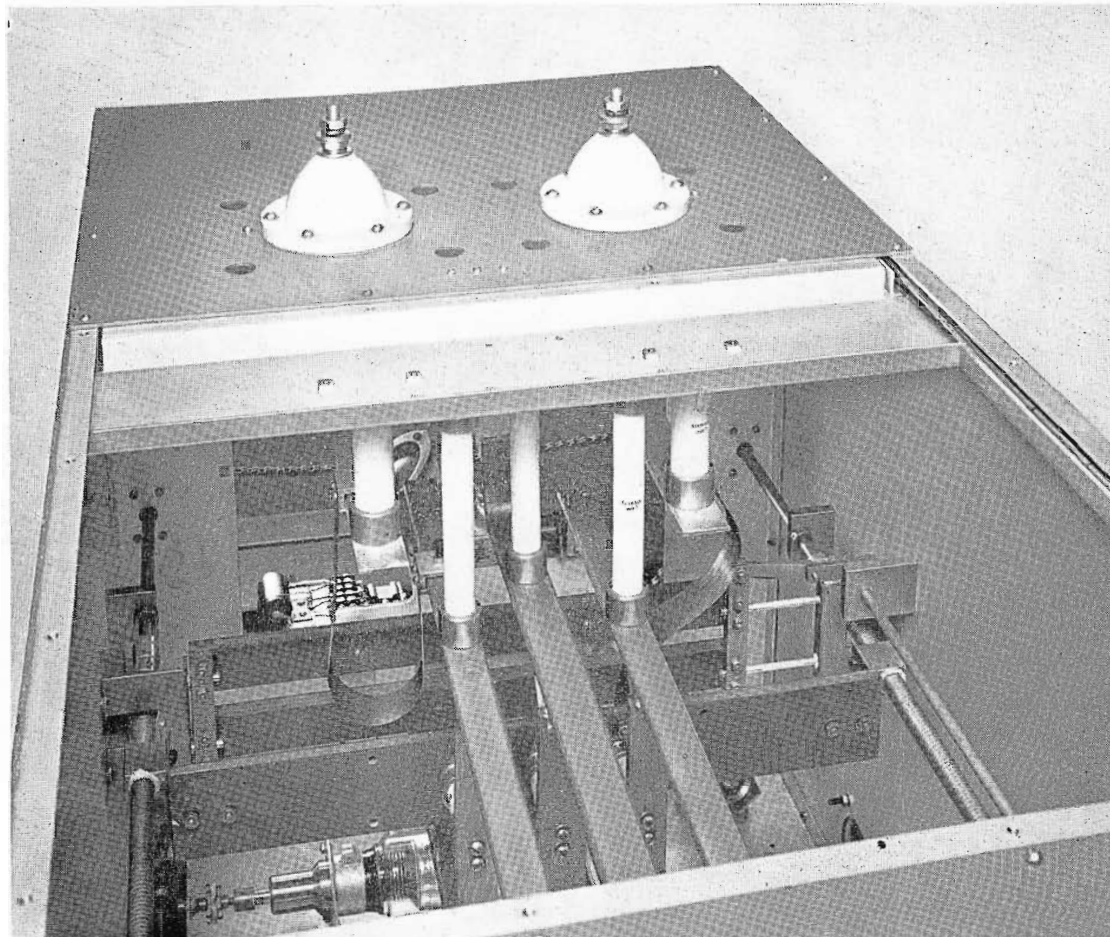

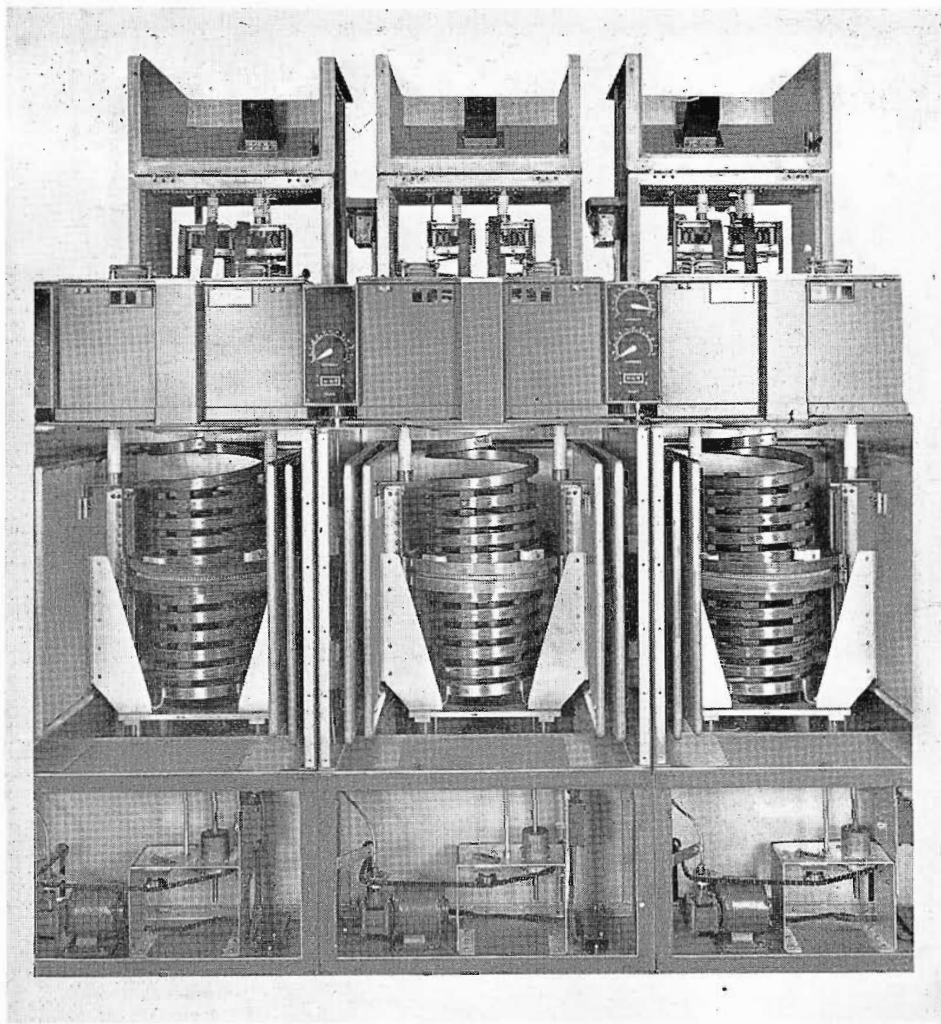

FIG. 8. Final Amplifier (Front View) showing plate circuit elements and tuning drives.

switches are located external to this shielding to eliminate any chance of radiation from control or power leads.

The 9C25 grid is tied to ground through four ceramic blocking capacitors placed symmetrically around the tube. These capacitors are low inductance units and their placement helps to distribute the r-f currents equally around the circumference of the tube. No neutralization is required under any condition of operation, and tests showed the amplifier to be entirely stable under any tuning condition.

The plate tank circuit consists of a variable inductor, mounted coaxially to the tube radiator axis and directly below it. A fabricated blocking capacitor, in the form of a U is folded around the coil, and its capacity to the cabinet walls acts as the output coupling capacity. The inner shell of the amplifier cabinet forms a low

inductance path for the tank current, effectively shielding against any radiation. As in the filament circuit all control and tuning motor leads are kept entirely outside of the cabinet walls.

Fig. 8 is a front view of the output amplifier showing the physical location of the tank coil assemblies. The 9C25 tube is located directly above the coil, on a sheet of mycalex, which acts as an insulating support for the tube and an air barrier to form a plenum chamber for cooling purposes. The actual tube socket with its corona ring can be seen above the coil. The plate blocking capacitor folds around the actual inductor to form a U, with the outside plate acting as the output coupling capacitor. Note that the circulating current flows through the active coil turns, thence through the blocking capacitor, and back up to the grid separation plane and through grid blocking capacitors,

shown on Fig. 10, to the tube element. Through this arrangement all currents are contained within the amplifier shell which, because of the large area low current density path, represents an extremely small portion of the total plate circuit allowing sufficient coil inductance for satisfactory operation at 26 megacycles. (About one active turn is in use at this frequency.)

For convenience of maintenance, the entire assembly of coil and inner blocking capacity plate can be readily removed from the amplifier cabinet, as shown in Fig. 9. These units are identical in both the output and driver amplifiers. The inductor is space wound on sturdy internally located mycalex spacers, and is mounted on a dural base, cut out to allow for the passage of cooling air. This base, when attached to the inner blocking capacity plate, with aluminum brackets, forms a rigid assembly, and places a low inductance short on the unused portion of the inductor.

A metallic ring, incorporating a gear of slightly smaller diameter than the ring, varies the inductance by rotating around the coil. Rotary motion is imparted to the ring through two non-metallic pinions which slide on their square drive shafts, while a vertical motion corresponding to the pitch of the coil turns is obtained from 4 equally spaced rollers, located one turn below the main contacts, mounted on the ring and engaging between the coil turns. These rollers are located on the ring so that the ring is held horizontally and moves up or down as the case may be, so that the current carrying contacts are automatically aligned with the coil turn. The main current carrying contacts are graphite bearing copper shoes, machined to the coil radius, and held under spring tension, with free pivoting guides giving restricted movement in all planes. Auxiliary contact springs serve to prevent random arcing as the rollers progress along the coil turns, and allow for irregularities in coil pitch. All sliding contacts are accessible for inspection, cleaning or replacement as required, without removing the complete coil assembly.

The electrical performance of the assembly was completely satisfactory, with no



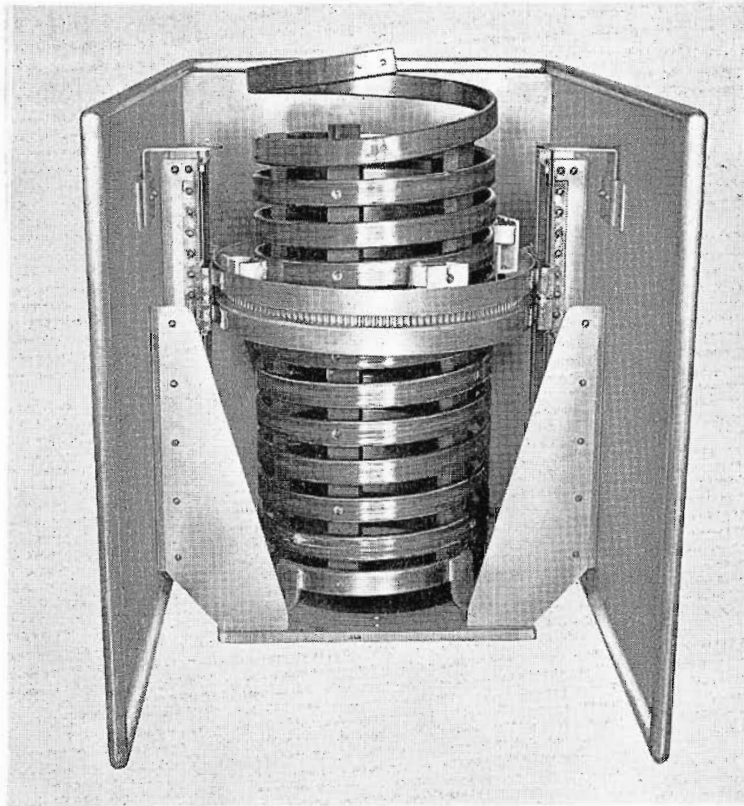

FIG. 9. Final Amplifier Plate Tank Coil Assembly removed from amplifier.

The inductance of both the primary and the secondary take the form of rectangular loops or U's, placed coaxially and parallel. Three turns are used, with the center turn acting as the primary. The two secondary turns are connected either in series, through an r-f band switch so that a two turn coil results, or, in parallel so that a single turn results. The inductances of both primary and secondary are varied simultaneously by means of a motor driven shorting bar.

This physical arrangement results in a substantially constant mutual coupling over the entire frequency range, and permits satisfactory control of transmitter loading without the complications which would be introduced by making the coupling variable. For a nominal load impedance value of 600 ohms, the transmitter output is taken from across the entire secondary coil. For load impedances of lower value, the output is taken off at an appropriate impedance point on the secondary coil. To prevent unbalancing effects at the fundamental frequency and to minimize transmittal of harmonic power, electro-static shields are provided in the form of non-magnetic troughs fitted over the major portion of the primary turn.

additional shorting points required at the top frequencies, although it had been expected that additional shorting points might be necessary to break up resonances in the short circuited unused portion of the coil. Both measurements and actual performance checks indicated that neither the shorted turn formed by the shorting ring nor the actual coil turn enclosed by the four main and auxiliary contacts caused any appreciable degradation of coil performance because of losses.

The two output amplifiers are coupled together at the 9C25 anodes, with a low inductance strap connector through an interconnecting duct. This connection stabilizes operation and permits non-critical tuning of the separate amplifiers. Power is fed from the output amplifiers through a 50 ohm coaxial line to the output circuit and control of loading is accomplished by adjustment of the primary capacity in the output circuit.

#### Output Circuit

This unit combines the outputs of the two final amplifiers and converts their output from unbalanced power to balanced power. At the same time it functions as an impedance transformer and as a har-

monic attenuator. Essentially, the output circuit consists of a fixed coupled transformer with a parallel tuned unbalanced primary and a parallel tuned balanced secondary.

FIG. 10. Top View of Final Amplifier showing grid-blocking capacitors and tube socket. Exhaust air hood opened.

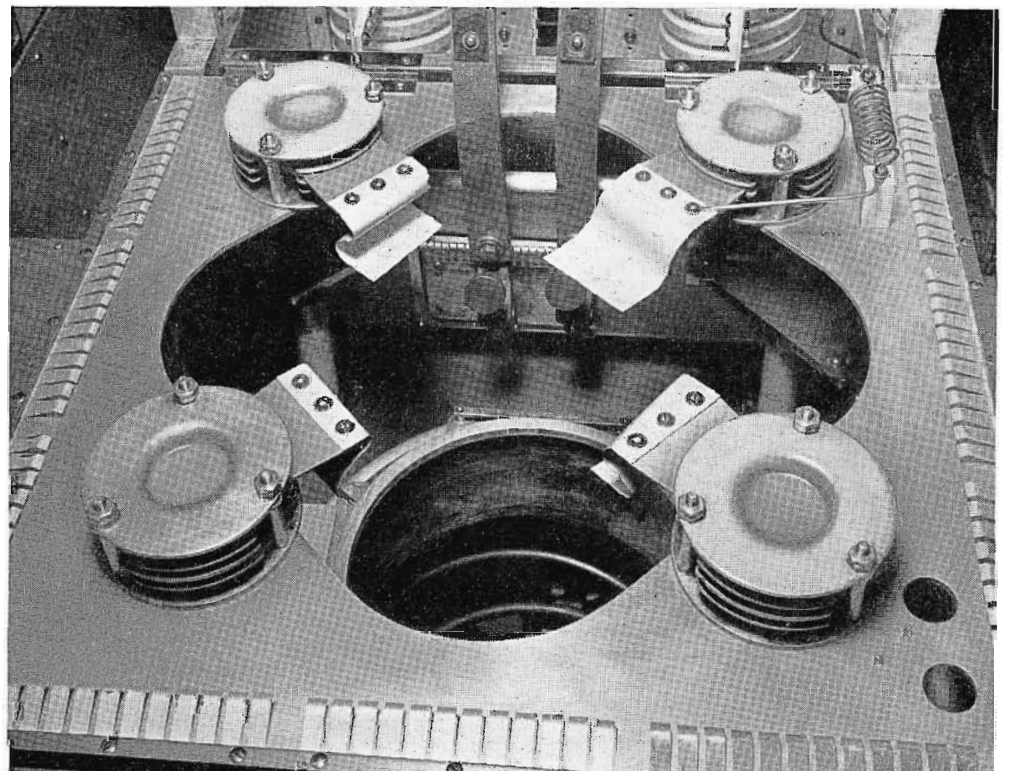

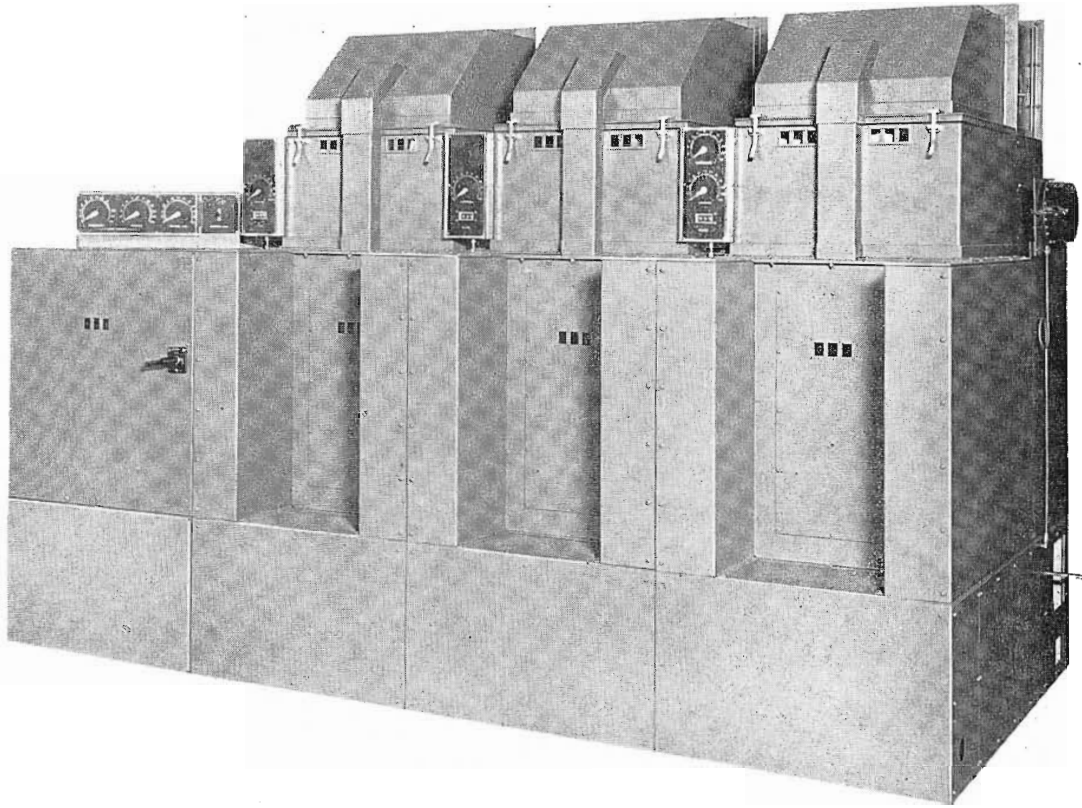

FIG. 11. Final Amplifier and output circuit assembly illustrating degree of R-F shielding.

The entire output circuit is enclosed and all control elements are located external to the r-f area. This results in good accessibility and prevents possible radiation from control and turning motor leads.

#### Audio Section

The audio frequency section, with the exception of the modulation transformer and reactor, is housed in a single cabinet. The audio section consists of the voltage amplifiers and driver sections, the modulators and the low voltage audio power supplies.

Push-pull circuits are used throughout the audio chain. Low power circuits consist of a two stage voltage amplifier which is followed by a zero voltage gain, cathode follower type amplifier which drives the amplifier grids directly from voltage developed across the cathode networks. A total of eight 813 tubes are necessary to provide peak grid current to the modulator grids.

The modulator stage uses tubes of the same type as the r-f amplifiers, operating

as Class B amplifiers. The proper choice of modulation transformer ratio and modulator d-c plate voltage provide adequate output for completely modulating both the driver and the final amplifiers. Feedback is applied from the modulator plates to the grids of the input voltage amplifier through a resistance capacity network having zero phase shift at frequencies much higher than that of the highest modulating frequency. An "L" section, low pass filter located between the modulation transformer and the power amplifier serves to attenuate spurious frequencies and to maintain constant modulator output impedance up to 10,000 cycles per second.

The modulator tubes have individual cathode current meters and over-current relays for indication and tube protection similar to those used in the r-f chain.

Plate voltage for the voltage amplifiers and the cathode follower is supplied by a full wave, single phase rectifier in the modulator. Bias voltages for the cathode follower and modulator grids are supplied by a metallic rectifier through an adjustable bleeder.

#### Rectifier

The main rectifier supplies plate voltage for all radio frequency amplifiers. It consists of six RCA 857-B mercury vapor tubes, connected in a three-phase, full-wave, center tapped circuit. A seventh tube socket provides for a pre-heated spare tube which can be switched to replace any of the operating tubes.

The plate transformer is a three-phase, air-cooled unit. Reduced voltage (approximately 57 percent of full voltage) for transmitter tune-up is provided by means of a manually operated switch. The switch is located on the control and distribution unit and is mechanically interlocked to prevent improper operation and possible damage to the equipment.

The smoothing filter for the three-phase full-wave (9000 volt) supply is a single section inductance input filter. A protective resistance in series with the capacity leg limits surge currents through the amplifier and modulator tubes. The smoothing filter for the three-phase half-wave low voltage supply is a two section inductance

input filter, with series resistance in the output capacity leg to limit surge currents. An electrically opened, gravity closed contactor grounds both high voltage outputs in the rectifier by shorting the filter capacitors when the rectifier cabinet door, or any other interlocked door in the transmitter, is opened.

### Power Distribution and Control

The power distribution, protection, and control functions are localized in one unit. This unit is divided into two sections; one section containing the power feed and distribution circuits and the other, the control circuits.

The 460 volt, three-phase power supply line for the equipment is connected to the main air circuit breaker. When this breaker is open, the entire equipment is electrically dead except for 115 volt circuits supplying utility outlets. A distribution air circuit breaker feeds all low power circuits, fila-

ments, blowers, etc., through a 460 to 230 volt distribution transformer and an automatic induction type voltage regulator. Branch circuits for the blowers and filaments include the air circuit breakers and contactors required for protection and for correct functioning of the control system.

The main rectifier is fed through automatic induction-type voltage regulators (located external to the control and distribution unit) the rectifier air circuit breaker, and the reduced voltage switch. In this circuit the reduced voltage switch is interlocked for cold break switching only, since operational switching and overload protection are handled by the air circuit breaker. The high power air circuit breakers are trip-free, mechanical latch types for fast interruption under fault conditions.

The control system performs several functions, including starting up and shutting down the transmitter with automatic

sequencing of the various starting operations. It also provides protection of the tubes and equipment against faults and improper operation. The relays and contactors associated with these functions are located in the control and distribution unit. Most of the control and operating switches are located on the front panel of the transmitter.

Provision has been made for selective fault protection. Indicating means have been included to identify different fault conditions with regard to location and type. An open circuit, or loss of control voltage in any part of the control system, will shut down the equipment.

### Acknowledgment

Engineers who contributed to the design were: R. R. Hutt on audio frequency circuits, R. A. Henderson on lower power radio frequency circuits and T. N. Newman on overall mechanical features.

FIG. 12. Push-pull, Class B Modulator with voltage amplifiers and cathode follower.

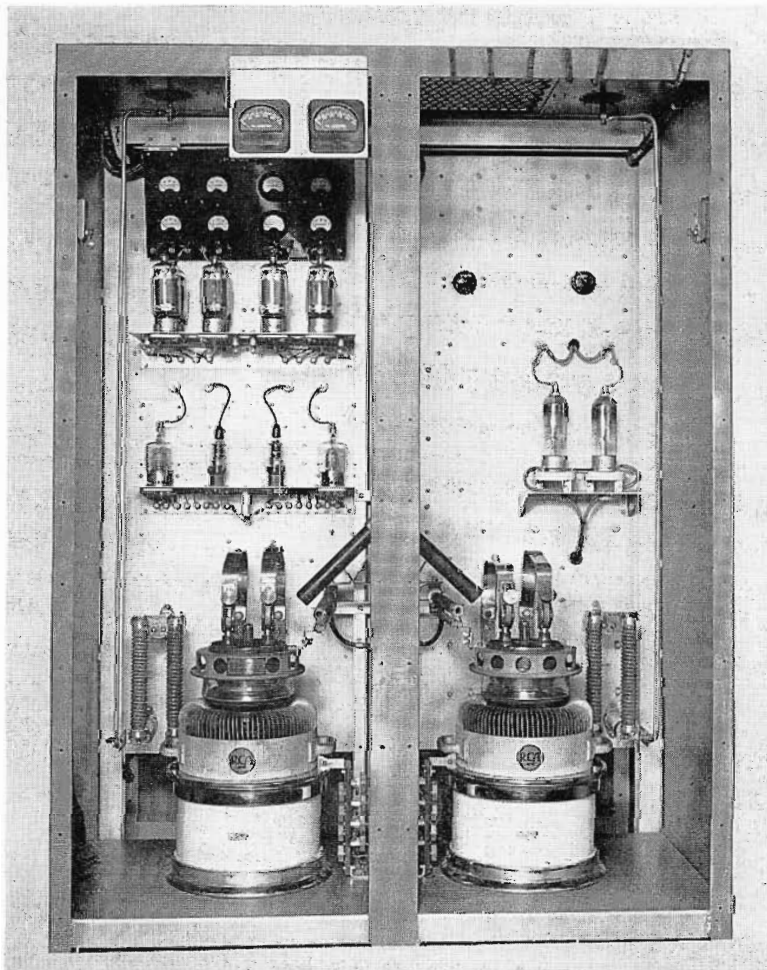
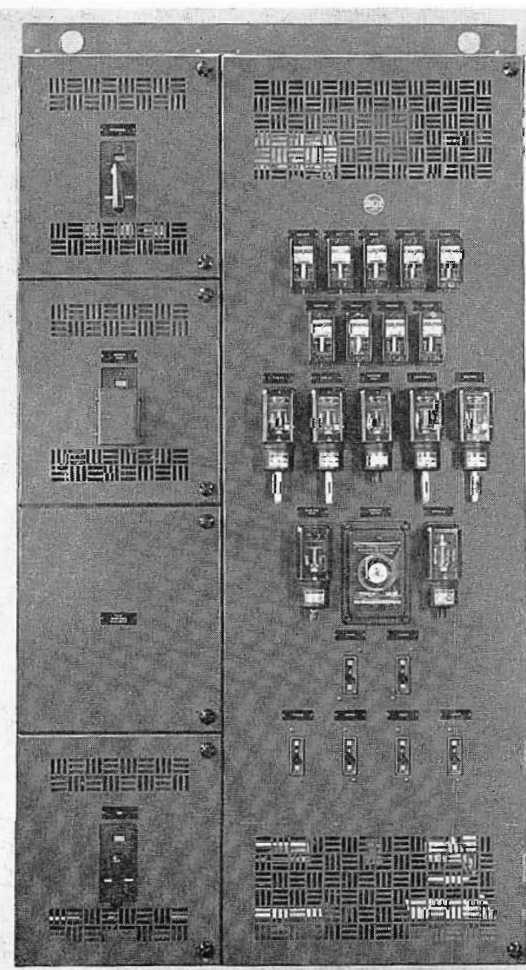

FIG. 13. Power Distribution and Control Unit showing location of overload relays.





Actually, the sequence of events, though rapid, was not that simple, for it involved the activities of two other hams, W4DEK and W4RRS, both of Knoxville. W4RRS managed to locate the Atlanta Journal's Sports Editor, Fuhman Bisher, in his hotel in Knoxville, but W4DEK finally transmitted Bisher's story to W4DAL who recorded it on tape and "patched" it to the newspaper. Needless to say, the Atlanta Journal was very happy about P. G.'s highly successful efforts.

P. G., who is RCA's Broadcast Representative in the Atlanta Office, is active on 10, 20 and 75, fixed and mobile. A 32V-2 feeds two 3-element closed-spaced rotaries on 10 and 20.

### FIRST QSO IN MANY YEARS FOR THIS OLD TIMER

Below is Wally Watts, Vice President of RCA Engineering Products Department, once again trying his hand at ham radio while visiting Bob Welsh, W2PTM, Haddonfield, N. J. Though momentarily captivated by an interesting W6 contact (note Bob's pleased expression), Wally, who has held many ham tickets dating from 1919, has no plans for again becoming active.

Bob Welsh, W2PTM, looks on as Wally Watts, Vice President of RCA Engineering Products, "gets the feel" of ham radio after many years being inactive.

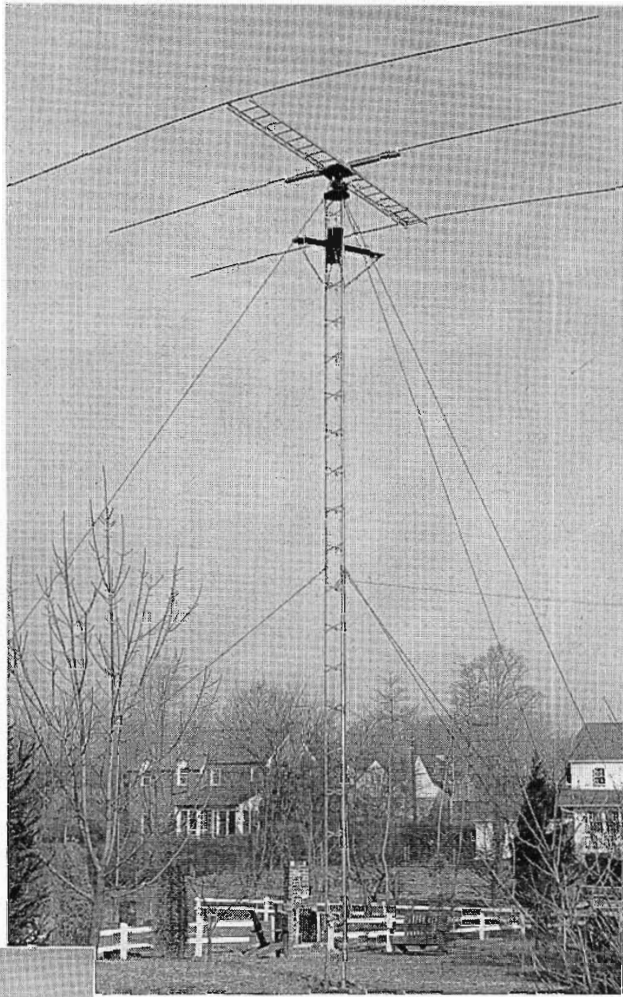

Bob's 20-meter rotary, perched on a 40-foot triangular tower, is inductively coupled to a low-impedance open-wire line.

We thought you would like to see these two pictures of well known hams (bottom of page) which Bob brought from Copenhagen following two weeks attendance at the International Air Transport Association Conference held there last year. . . . Bob and his XYL visited Bill Parker, G6BY, and Hans Peterson, OZ3EA. G6BY runs 100 watts, but a multi-wave rhombic on 600 acres of high country is responsible for the consistent signal he lays into the States. OZ3EA (whose XYL is licensed OZ2EA) has a "V" beam stretched over the top of several buildings. . . . Hans uses NBFM. —73.

Below, left, are G6BY and XYL, "Vi." In other picture, l. to r. are: OZ2EA, "Edie," XYL of OZ3EA; OZ3EA; and "Kae," XYL of W2PTM.

On the other hand, W2PTM (EXW3COT) RCA Planning Manager, is going strong on 20 in spite of the unpredictable band, and frequently works 2-meter aeronautical/mobile from his Ercoupe. He recently installed

the 3-element rotary pictured above, which no doubt helped him get elusive contacts like MF2AA and GD2-FRU. His power is 250 watts to a pair of 4-65A's modulated by 808's. . . .

Address correspondence to:  
**HAM FORUM**  
**Marvin L. Gaskill (W2BCV)**  
**Associate Editor, Broadcast News**  
**RCA, Camden, New Jersey**

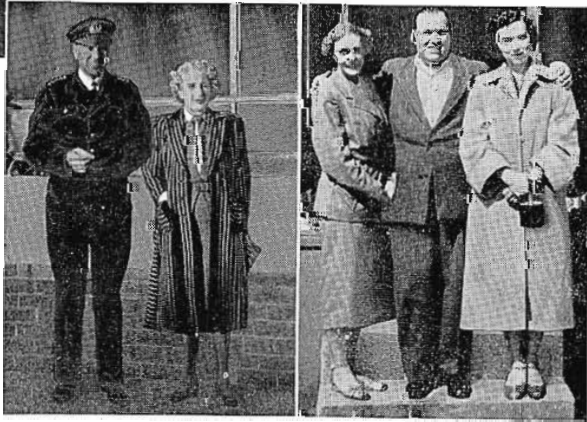

# Here's 4 reasons why—

## RCA is your best buy in 2-way radio



**1.** Top performance in tough territory . . . razor-sharp reception in metropolitan areas crowded with adjacent stations . . . where spurious signals may cause interference.



**3.** Single-unit design for easy installation . . . Case mounts on floor or wall of vehicle; right or left hand. Takes less space, provides easy access for servicing.



**2.** Rugged construction for rough duty . . . vibration tested, shock tested. Treated to resist humidity, to operate in arctic or tropic weather.



**4.** RCA-built, RCA-serviced for complete satisfaction . . . backed up by the world's greatest name in radio. Performance exceeds FCC requirements. Uses standard easy-to-get tubes. Continuing service provided by RCA Service Company if desired.

### Get full story . . . mail coupon **TODAY**

Find out about RCA 2-way radio for your particular application. Now used by police, firemen, highway crews, construction men, truck and taxi operators, utilities, pipe lines, others. Get big free illustrated booklet . . . now.

**FREE BOOKLET . . . MAIL COUPON**



**RADIO CORPORATION of AMERICA**

Dept. 129M, RCA Engineering Products, Camden, New Jersey

Please send me my FREE copy of illustrated booklet on how RCA 2-way radio can help me in my business checked below:

- General industry (Utilities, Construction, Petroleum, Lumber, Mining, etc.)
- Transportation (Truck, Bus, Taxi, etc.)
- Public safety (Police, Fire, Ranger, etc.)

Name \_\_\_\_\_ Title \_\_\_\_\_

Organization \_\_\_\_\_

Address \_\_\_\_\_

City \_\_\_\_\_ State \_\_\_\_\_



IT'S UNOBTUSIVE. Umber gray coloring blends it right into the TV picture. Minimum reflection.



IT'S COMFORTABLE TO HANDLE . . . weighs only 1 lb.

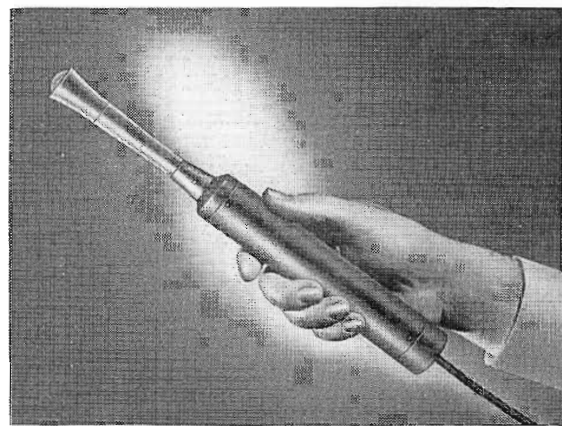

IT'S SMALL. Diameter of body is only 1¼ inches. Diameter of pick-up point is only ⅜ inch!

**In the show . . .**  
**without stealing the act**  
 RCA's new ribbon-pressure **"STARMAKER"\***

SO SLIM YOU MUST LOOK sharply to see it . . . so skillfully styled its shape and coloring fade right into the scene . . . this tubular microphone has won the favor of entertainers and announcers wherever it has been shown.

Designed by RCA Laboratories after more than three years of painstaking research, the STARMAKER meets the long need of broadcasting, television, and show business for a high-fidelity microphone that—will not hide the features of performers—is easier to handle—and yet retains all the high-quality features of RCA professional microphones. Pick-up is non-directional. Frequency response is uniform, 50 to 15,000 cps.

Here is a "carry-around" microphone free from wind blast and air rumble. It contains no tubes, no condensers, no high-impedance circuits, no special amplifiers, or power supplies—is virtually impervious to mechanical shock.

The STARMAKER fits any standard microphone stand . . . and can be substituted for any professional high-quality RCA microphone. *No extra attachments needed!*

For price and delivery, call your RCA Broadcast Sales Engineer. Or write Dept. PB 19, RCA Engineering Products, Camden, N. J.

*\*Selected from entries submitted by Broadcast Stations in national contest.*



**AUDIO BROADCAST EQUIPMENT**  
**RADIO CORPORATION of AMERICA**  
**ENGINEERING PRODUCTS DEPARTMENT, CAMDEN, N. J.**

In Canada: RCA VICTOR Company Limited, Montreal

Completely **NEW**

**5-kw AM...\***

*New small size-*



1. Increase power to 10 kw with this simple kit



\*RCA ALL-NEW 5-kw AM transmitter, Type BTA-5G. The 10-kw Type BTA-10G is same size, same appearance. Maximum floor area, only 33 sq. ft. Both transmitters are completely air-cooled.



# ...with a "10-kw" future!

**New operating convenience - New operating economy**

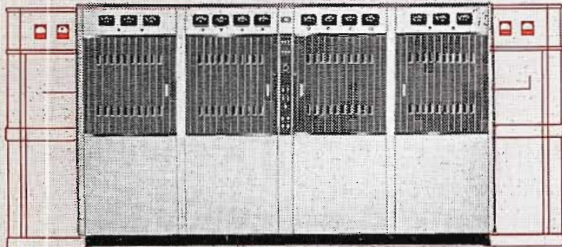

2. Up to 40% less floor area than previous "5 kw's"

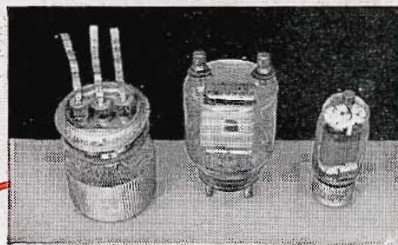

3. Power tube costs reduced

## Just read these exclusive features . . .

- 1 It is a 5-kw AM transmitter you can increase to 10 kw—easily—inexpensively—quickly. No lost air time for conversion. One simple kit makes it easy to increase power overnight. (Yes, you can buy this transmitter ready-built for 10 kw, too).
- 2 It requires less "operating" floor space than other 5 kw's—saves up to 40% floor area. Entire transmitter is only 84" high, 130" wide, 32½" deep.
- 3 It's the ONLY "5 kw" with such low tube costs. Power and modulator stages use the new small size, lightweight RCA-5762—costing less than half that of power types in most "5 kw's".
- 4 It's the ONLY "5 kw" with "split-cycle" overload and voltage protection—using thyatron-controlled rectifiers. Circuits work so fast audiences cannot detect "off-air" breaks.
- 5 It holds power bills to the LOWEST in the "5-kw" field—through smaller power tubes, fewer stages, fewer tubes (only 24 tubes and 8 different types).
- 6 It's the ONLY "5 kw" with horizontally-sliding doors *front and back*. Benefits:
  - ✓ Saves over 60 square feet of floor area
  - ✓ Provides more elbow room for operator
  - ✓ Makes it easier to get at transmitter

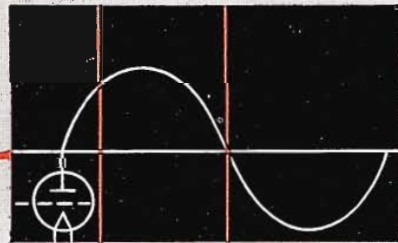

4. 1/60th second arc-back protection

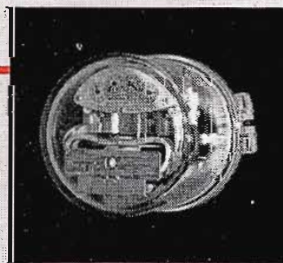

5. Lower power bills

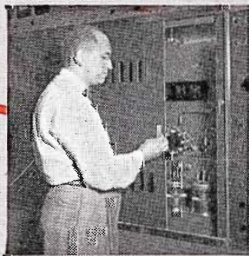

6. Sliding doors—  
front and rear

For all the facts about this basically new transmitter . . . newest of nearly three hundred RCA "5-kw's" now on the air . . . call your RCA Sales Representative.



**RADIO CORPORATION of AMERICA**  
ENGINEERING PRODUCTS DEPARTMENT

CAMDEN, N. J.

## RCA ANNOUNCES

# A new advanced film-camera for television...

THIS NEW FILM CAMERA does for TV film presentations what RCA's new TK-11A studio camera is doing for "live" pick-ups. The TK-20D camera pro-

vides a remarkable advancement in picture quality and operating convenience over former types—puts "live" quality into films regardless of scene content or shading. Low picture noise level compares with the low noise level of "live" pick-ups.

Operated in conjunction with an RCA TP-9B Film Multiplexer, one TK-20D Film Camera provides show continuity with any one of the following set-ups: (1) two RCA TP-16D 16mm Film Projectors, (2) two RCA

TP-6A Professional Film Projectors, (3) two RCA 35mm Film Projectors, (4) one 16mm and one 35mm Film Projector, (5) or one projector of either type and a slide projector.

With TV programming emphasis more and more on films, let us help you get the most from film—with the new TK-20D. Your RCA Broadcast Sales Representative is ready to help you plan the right film system for your station—with everything matched for best results!

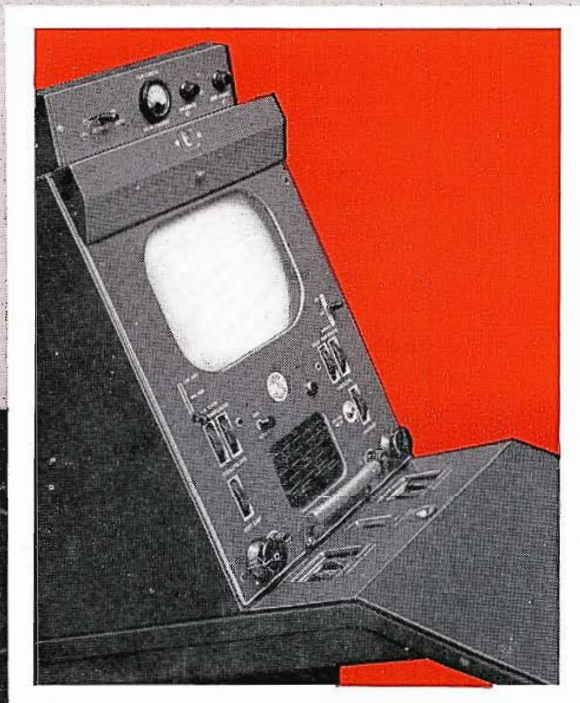

Iconoscope beam current control, with indicator. A new arrangement that takes the guesswork out of day-to-day adjustments—provides a standard of comparison to help the operator adjust for optimum picture quality. The panel mounts on the housing of the film camera console, or in the remote control console.

A vintage RCA television set, model TK-20D, is shown in a studio setting. The set is a tall, dark-colored cabinet with a large screen at the top. It features a prominent metal handle on the right side and a control panel on the left. The RCA logo is visible on the top left of the cabinet. The set is positioned on a dark, tiled floor. Red arrows point from the text blocks to various parts of the television set.

# ... Type TK-20D

● "Live" quality all the time—regardless of scene content, shading, or other adjustments. New back-lighting system, and new automatic black-level control permits the TK-20A virtually to run itself!

● "Noise-free" pictures comparable to "live" shows. New high-gain cascode preamplifier, with "noise-immune" circuits, offers 200-to-1 improvement in microphonics. No high-frequency overshoot (trailing white lines). No low-frequency trailing (smear).

● Good-bye edge flare. New edge-lighting system provides substantial reduction in stray light, improves storage characteristic, stops light beam reflections on Iconoscope mosaic. Adjustable light level is provided.

● No more a-c power line "glitches" (horizontal-bar interference)—because camera filaments are operated from a separate d-c source.

● Faithful, high-quality pictures every day—through new beam-current control circuit. No more need to "ride" the shading.



**RADIO CORPORATION of AMERICA**  
ENGINEERING PRODUCTS DEPARTMENT

CAMDEN, N. J.



**RCA Velocity  
Microphone  
Type 44-BX**  
Effective Output Level, -55 dbm  
Hum Pick-up Level, -112 dbm



**RCA Polydirectional  
Microphone  
Type 77-D**  
Effective Output Level, -57 dbm  
Hum Pick-up Level, -126 dbm

# Broadcasting's Best...

These are the network favorites.

Year after year they serve more broadcast and television audiences than any other microphone. Yet, despite their overwhelming popularity, RCA's engineering continues to make both even better than before.

The 44-BX is the bi-directional type—designed for AM, FM, and TV studios where highest quality reproduction is desired. It provides high-fidelity output over the entire audio range—and is free from cavity or diaphragm resonance and pressure doubling.

The 77-D is the polydirectional type . . . quickly adjustable to *any* pick-up pattern you want. A 3-position voice-music switch enables you to select the best operating characteristic for voice and music. *Hum pick-up level, -126 dbm!*

Call your RCA Broadcast Sales Engineer for prices and delivery information. Or write Dept. 19 JB, RCA Engineering Products, Camden, New Jersey.



**BROADCAST EQUIPMENT  
RADIO CORPORATION of AMERICA  
ENGINEERING PRODUCTS DEPARTMENT, CAMDEN, N.J.**

In Canada: RCA VICTOR Company Limited, Montreal